

RoHS Compliant

REV.	ECN NO	LTR	DESCRIPTION	REVISER	DATE
A/0			Initial release.	HCZ	2021.09.28

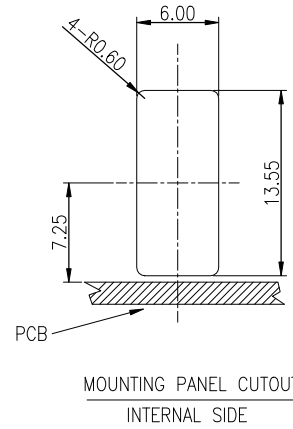
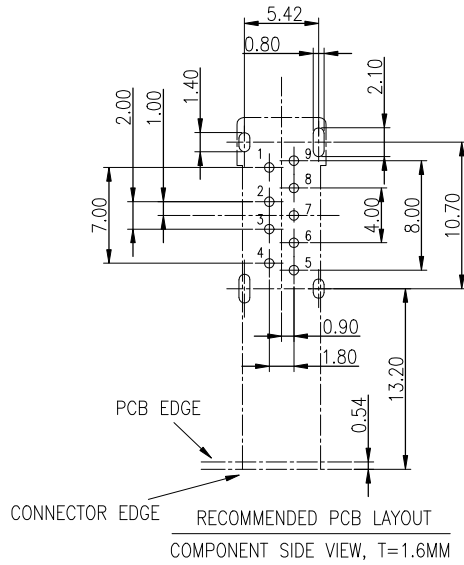
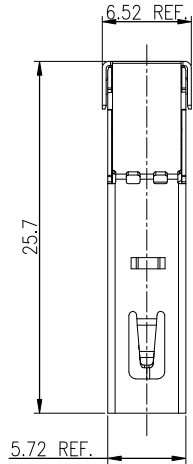

NOTES:

- MATERIAL:
HOUSING: THERMOPLASTIC PA9T+30%GF, HALOGEN FREE, UL94V-0, COLOR: BLACK.
USB 3.0 TERMINAL: BRASS C2680R/H
USB 2.0 TERMINAL: PHOSPHOR BRONZE C5191R/H
SHELL: STAINLESS STEEL 304
- FINISH:
TERMINAL:
CONTACT AREA: GOLD 1u" Min PLATED
SOLDERING AREA: MATTE TIN PLATING 100U" THICKNESS MIN.;
UNDER PLATING: NICKEL PLATING 50U" THICKNESS MIN. OVERALL.
SHELL:
NICKEL PLATING 50U" MINIMUM OVERALL
- ELECTRICAL CHARACTERISTICS:
CONTACT RESISTANCE: 30mΩ MAXIMUM
CONTACT CURRENT RATING: 1.5A
DIELECTRIC WITHSTANDING VOLTAGE: 500 V R.M.S.
INSULATION RESISTANCE 1000 MEGOHMS MIN
OPERATING TEMPERATURE: -25°C ~ +85°C
- MECHANICAL PERFORMANCE:
MATING FORCE: 3.57Kg.Max.
UNMATING FORCE: 1.02Kg.Min.
- THE DIMENSIONS WITH "▼" MARK ARE CRITICAL AND SHOULD BE CONTROLLED BY QC.

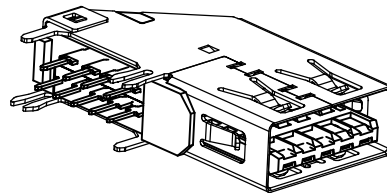
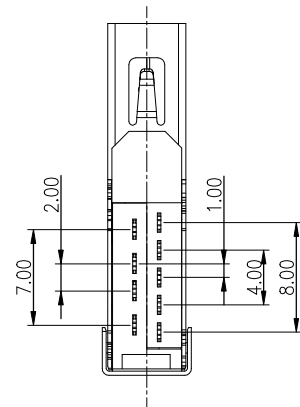
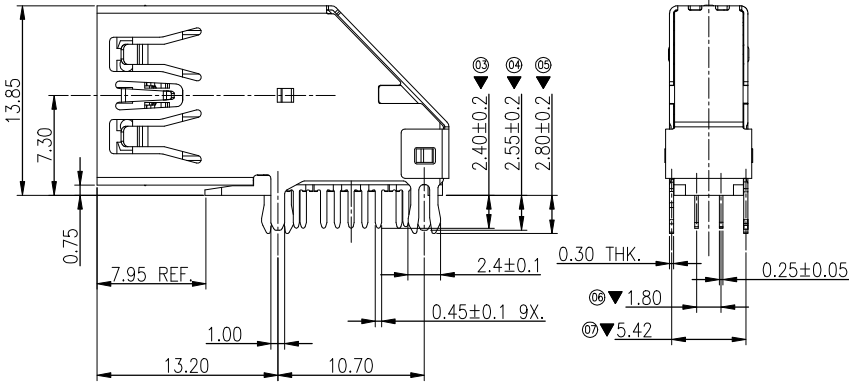
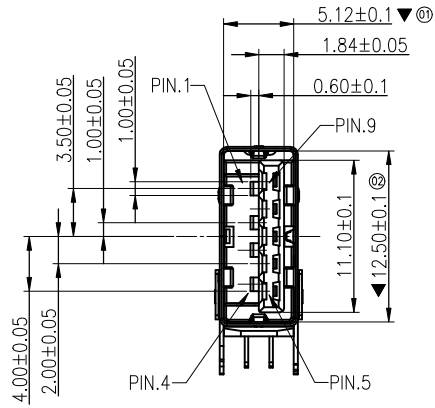

3D VIEW

图号 (DWG NO)	G-601-S1-549	单位 (UNIT): MM	显赫电子科技有限公司 XianHe Electronic Technology co., Ltd.
类别 (DWG TYPE)	SALES DWG	比例 (SCALE): 1:1	
版次 (REV): A/0	页次 (PAGE): 1/1		TEL: 0769-89138899 FAX: 0769-89100950
设计 (DESIGN)	HCZ	未注公差 TOLERANCE UNSPECIFIED	品名 (ITEM NO)
审核 (CHECKED)		.X.X ± 0.38 .X.XX ± 0.20 .X.XXX ± 0.10 * ± 5° .X.X' ± 2'	ASP A/F 90度 侧插DIP式 鱼叉脚, 无卷边, DIP=2.4mm, 黑色PA9T, 半金雾锡1U", 不锈钢镀镍48H, 无卤
核准 (APPROVED)			料号 (PART NO)
			601ASPALHF