

RoHS Compliant

REV.	ECN NO	LTR	DESCRIPTION	REVISER	DATE
A/0			Initial release.	JASON	2019.01.24
A/1		△	橙色增加色卡号PANTONE 021C	HCZ	2021.11.17
A/2		△	色卡号PANTONE 021C变更为PANTONE 2028C	HCZ	2021.12.07

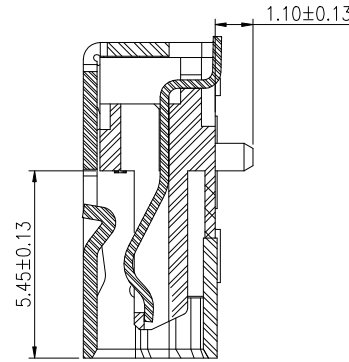
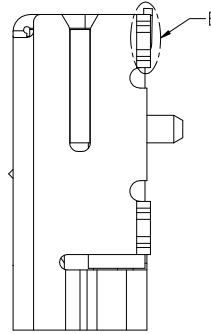
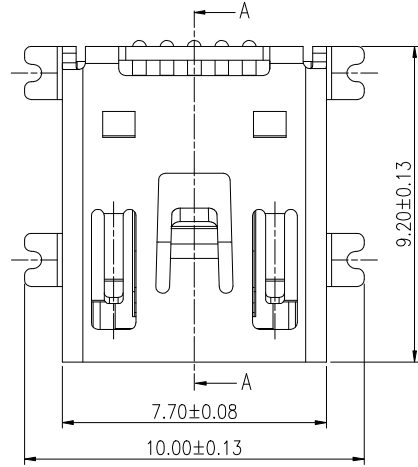

Section:A-A

NOTES:

1.Material:

1.Housing: PA9T+30%GF, UL 94V-0

Color:orange PANTONE 2028C △△

2.Terminal:Copper alloy

Gold on contact area and Tin on solder area

3.Shell:Copper alloy

50-100u"Min.matte tin plated on solder tail

50u"Min.nickel under-plated

2.Electrical specification:

1.Current Rating:1 Amperes at 250V AC.

2.Dielectric Withstanding Voltage:AC 750V at sea level.

3.Insulation resistance:100Megohms Min.

4.Contact Resistance:50Miliohms Max.

5.Operating Temperature:-55° to +85°

3.Mechanical characteristics:

1.Mating Force:3.57Kg.Max.

2.Unmating Force:0.70Kg.Min./0.3Kgf Min after 5000 cycles

4.THE DIMENSIONS WITH "▼" MARK ARE CRITICAL AND SHOULD BE CONTROLLED BY QC.

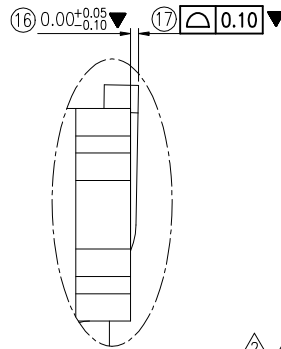
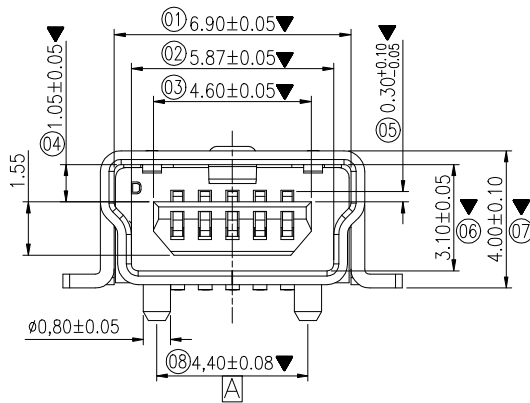

Detail:B

HOW TO DRDR:

312-5-F-X-A9-X-X

Hsg.color:

0:Orange

△△ (PANTONE 2028C)

Terminal plating:

-1:半金锡GF

-5:半金锡15u"

-6:半金锡30u"

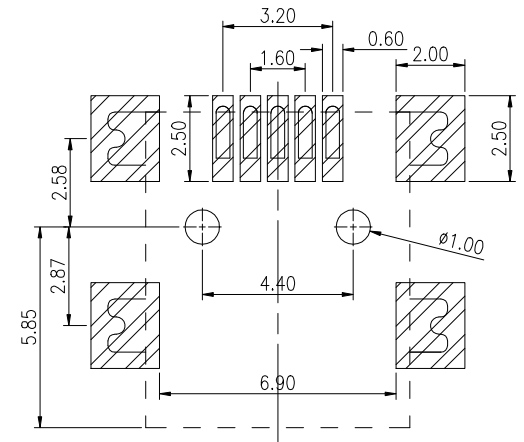

Recommended P.C.B layout

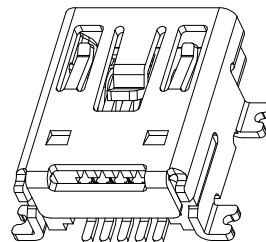
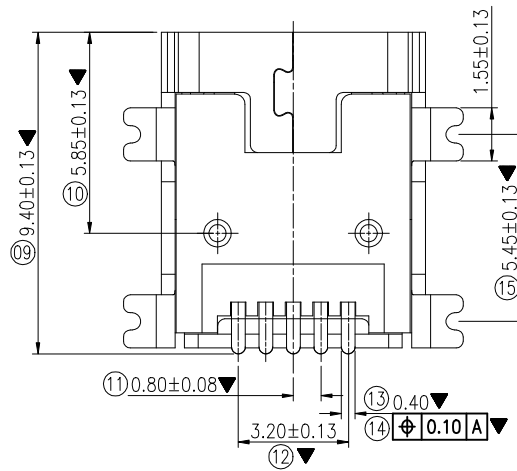

图号 (DWG NO)	G-312-S2-504	单位 (UNIT):	MM	显赫电子科技有限公司 XianHe Electronic Technology co., ltd.	
类别 (DWG TYPE)	ENG DWG	比例 (SCALE):	1:1		
版次 (REV):	A/2	页次 (PAGE):	1/1	TEL:0769-89138899 FAX:0769-89100950	
设计 (DESIGN)	MICHAEL	未注公差	TOLERANCE UNSPECIFIED .X.X ± 0.15 X.XX ± 0.10 X.XXX ± 0.05 * ± 2° X.X' ± 1°	品名 (ITEM NO)	MINI usb 5pin smt 母头 B type (加大拔出力款)
审核 (CHECKED)		核准 (APPROVED)		料号 (PART NO)	3125FOA9XX