

RoHS Compliant

REV.	ECN NO	LTR	DESCRIPTION	REVISER	DATE
A/0			Initial release.	Joe.peng	2017.07.26

NOTE:

1. MATERIAL:
- 1.1 INSULATOR-TOP:PBT+30%GF, UL94V-0, COLOR:YELLOW
 - 1.2 INSULATOR-BOTTOM:PBT+30%GF, UL94V-0, COLOR:BLUE
 - 1.3 COVER:PBT+30%GF, UL94V-0, COLOR:BLUE
 - 1.4 CONTACT 1~4/10~13PIN: C5191R/H T=0.20MM,
 - 1.5 CONTACT 5~9/14~18PIN: C2680R/H T=0.20MM,
 - 1.6 SHELL: C2680R-H T=0.30MM
 - 1.7 MIDDLE SHELL:C2680 T=0.30MM
 - 1.8 BLACK COVER:SPCC,T=0.30MM
2. PLATING:
- 2.1 CONTACT: SELECTIVE GOLD PLATED ON CONTACT AREA
100u" Min. TIN PLATED ON SOLDER TAIL
50u" Min. NICKEL UNDER-PLATED
 - 2.2 SHELL:50u" Min. NICKEL PLATED OVERALL
3. CHARACTERISTICS:
- 3.1 ELECTRICAL CHARACTERISTICS;
CONTACT RESISTANCE:30mΩ MAXIMUM
CONTACT CURRENT RATING:1.5A
DIELECTRIC WITHSTANDING VOLTAGE:500 V R.M.S.
INSULATION RESISTANCE 100 MEGOHMS MIN
OPERATING TEMPERATURE:-25°C ~ +85°C
 - 3.2 MECHANICAL:
MATING FORCE: 3.57Kg.Max.
UNMATING FORCE: 1.02Kg.Min.
DURABILITY TEST: 5000 CYCLES.
4. DESIGN STANDARD ACCORDING TO USB_3.0 SPECIFICATION.
5. THE DIMENSIONS WITH "▼" MARK ARE CRITICAL AND SHOULD BE CONTROLLED BY QC.

PART NUMBER INFORMATION
31930F-B-L9-X-BN-XX

- HF: Halogen Free
- W/O HF: RoHS
- Material of shell:
BN: Copper alloy with Nickel plating
- Terminal plating:
1: Gold flash
4: Gold 15u" on contact area.
6: Gold 30u" on contact area.

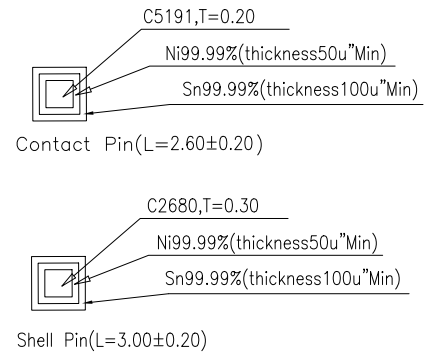
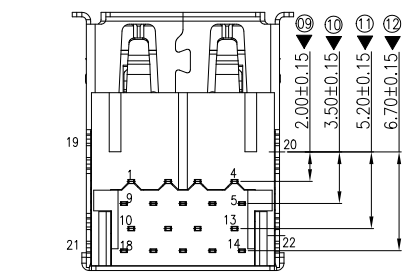
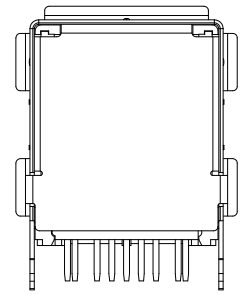
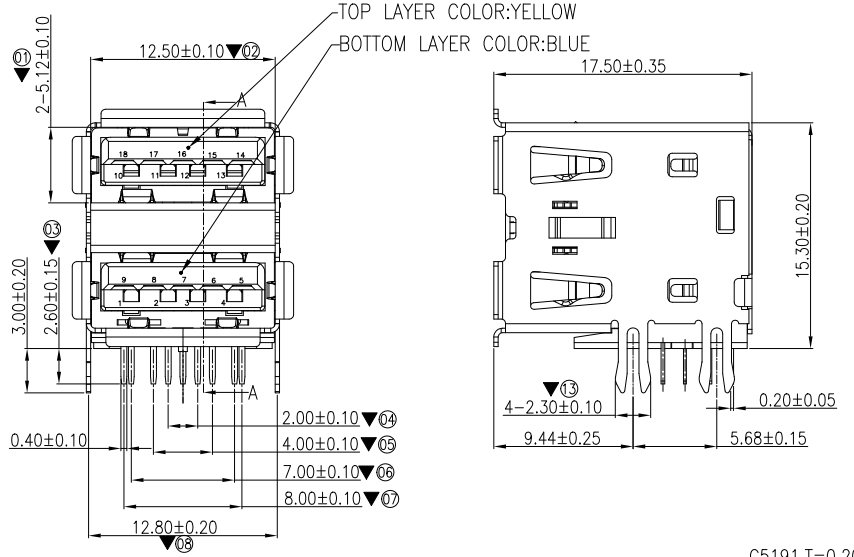
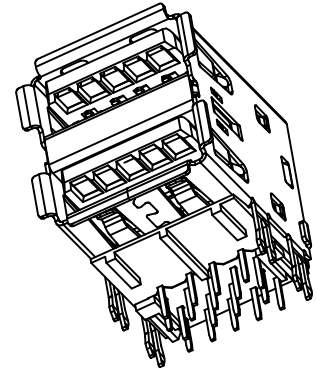
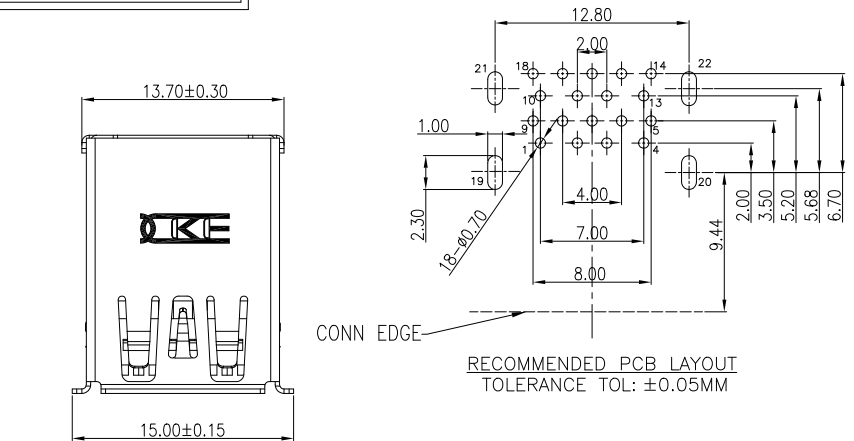

图号 (DWG NO)	G-319-S2-273	单位 (UNIT): MM		XianHe Electronic Technology co., ltd.	
类别 (DWG TYPE)	ENG DWG	比例 (SCALE): 1:1		TEL:0769-89138899 FAX:0769-89100950	
版次 (REV): A/0	页次 (PAGE): 1/1		品名 (ITEM NO)	USB 3.0 A/F 双层 90度 DIP 鱼叉脚 (上层黄色+下层蓝色)	
设计 (DESIGN)	Joe peng	未注公差 TOLERANCE UNSPECIFIED	料号 (PART NO)	31930FBL9XBNNX	
审核 (CHECKED)		.X.X ± 0.15 .X.XX ± 0.10 .X.XXX ± 0.05 " ± 2' .X.X' ± 1"			
核准 (APPROVED)					