

RoHS Compliant

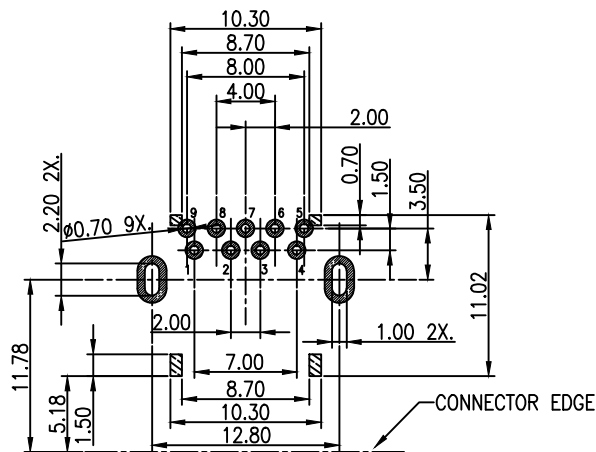

RECOMMENDED PCB LAYOUT
TOP VIEW, THK=1.6MM
KEEP OUT AREA.

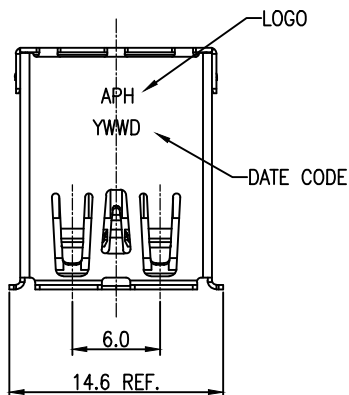
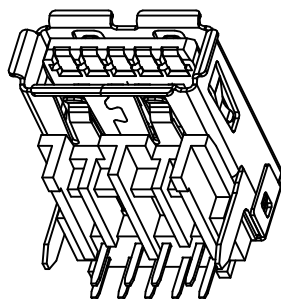
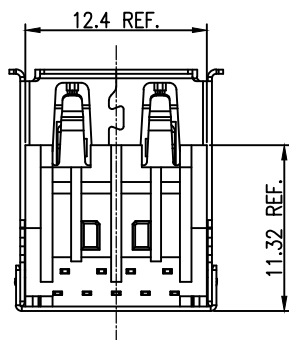
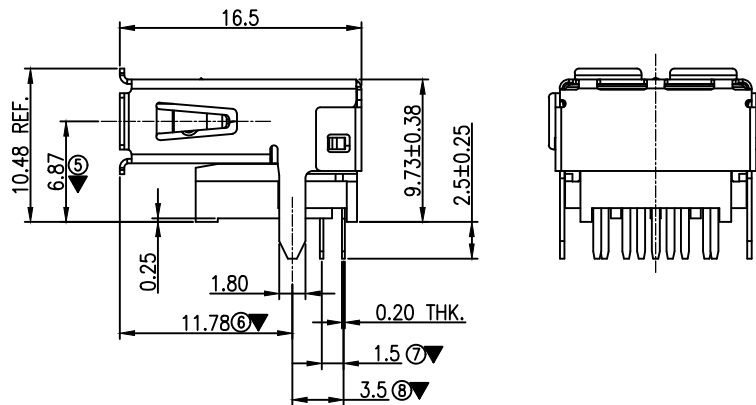
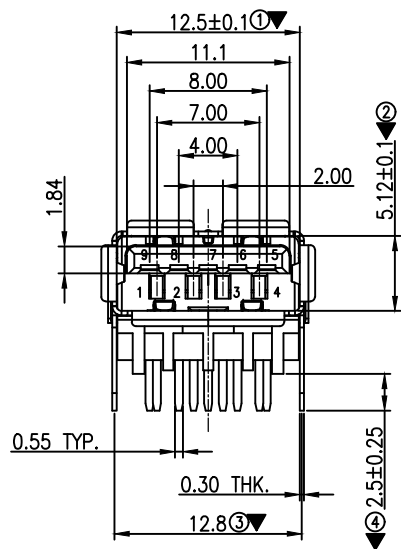

REV.	ECN NO	LTR	DESCRIPTION	REVISER	DATE
A/0			Initial release.	Mac	2016.04.26

NOTE:

1. MATERIAL:

- 1.1 INSULATOR: PA10T Vicnyl R630NH +30%GF, UL94V-0, COLOR:OPTIONAL
- 1.2 COVER: PA10T Vicnyl R630NH +30%GF, UL94V-0, COLOR:OPTIONAL
- 1.3 CONTACT 1~4PIN: C5191R/H T=0.25MM,
- 1.4 CONTACT 5~9PIN: C2680R/H T=0.20MM,
- 1.5 SHELL: STAINLESS STEEL 304 T=0.3MM

2. PLATING:

- 2.1 CONTACT: SELECTIVE GOLD PLATED ON CONTACT AREA 100u" Min. MATTE TIN PLATED ON SOLDER TAIL 50u" Min. NICKEL UNDER-PLATED
- 2.2 SHELL: PLEASE SEE THE PART NUMBER OPTIONS.

3. CHARACTERISTICS:

- 3.1 ELECTRICAL CHARACTERISTICS;
CONTACT RESISTANCE: 30mΩ MAXIMUM
CONTACT CURRENT RATING: 1.5A
DIELECTRIC WITHSTANDING VOLTAGE: 500 V R.M.S.
INSULATION RESISTANCE 1000 MEGOHMS MIN
OPERATING TEMPERATURE: -25°C ~ +85°C

3.2 MECHANICAL:

- MATING FORCE: 3.57Kg.Max.
- UNMATING FORCE: 1.02Kg.Min.

4. THE DIMENSIONS WITH "▼" MARK ARE CRITICAL AND SHOULD BE CONTROLLED BY QC.

PART NUMBER INFORMATION

31930F-X-F3-X-XX-XX

Hsg.color: _____
B: Blue(300 C)
K: Black

HF: Halogen Free
W/O HF: RoHS

Material of shell:
SN: SUS With Nickel plating
SBN: SUS With Black Nickel plating

REV _____

Terminal plating: _____

- 1: Gold flash
- 4: Gold Au 15u"
- 6: Gold Au 30u"

图号 (DWG NO)	G-319-S1-247	单位 (UNIT):	MM	显赫电子科技有限公司 XianHe Electronic Technology co., Ltd. TEL: 0769-89138899 FAX: 0769-89100950	
类别 (DWG TYPE)	SALES DWG	比例 (SCALE)	1:1		
版次 (REV):	A/0	页次 (PAGE):	1/1		
设计 (DESIGN)	Nelson	未注公差	TOLERANCE UNSPECIFIED	品名 (ITEM NO)	USB 3.0 A/F R/A DIP High-rise Center line=6.87mm
审核 (CHECKED)		XX	± 0.38	料号 (PART NO)	Please see P/N information
核准 (APPROVED)		XXX	± 0.20		
		XXX	± 0.10		
		X	± 5°		
		XX	± Z		