

RoHS Compliant

REV.	ECN NO	LTR	DESCRIPTION	REVISER	DATE
A/0			Initial release	Allen_Tsai	2021.03.16
A/1		△	DIP脚公差修改为+/-0.10mm	GENG	2021.06.08
A/2	2023041901	△	按照客户要求亮锡改成雾锡	WB	2023.04.19

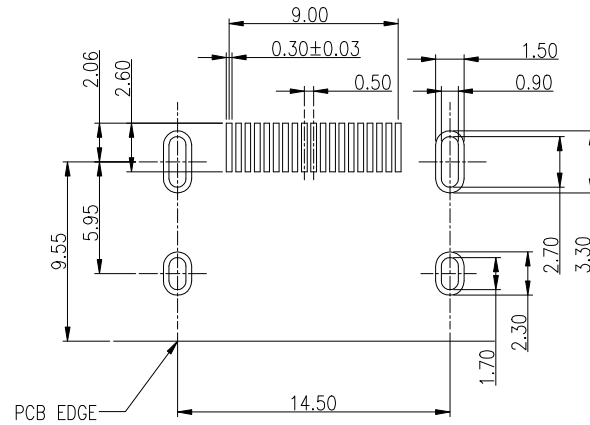

RECOMMENDED P.C.B LAYOUT  
TOLERANCE:±0.05

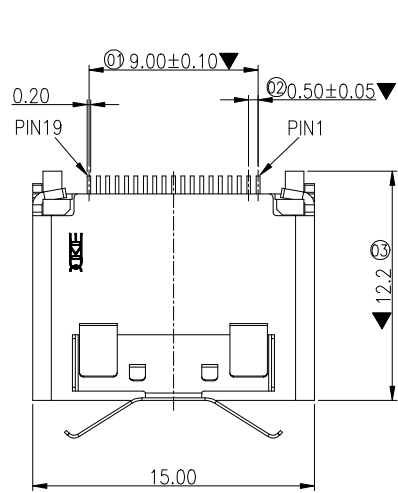
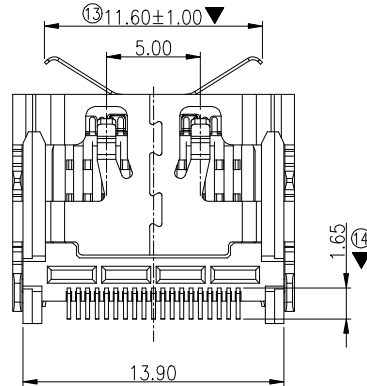
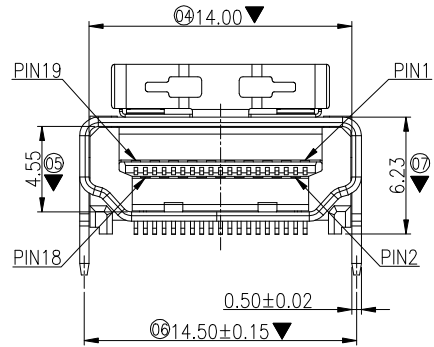
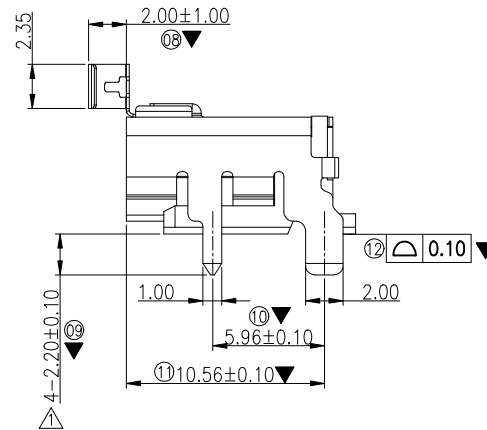
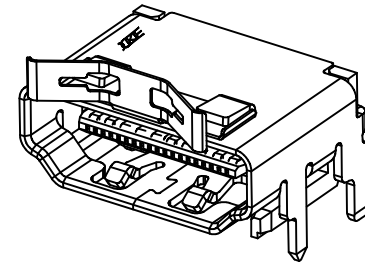

NOTE:

1. MATERIAL:

- 1.1 INSULATOR:LCP+30%GF, UL94V-0, COLOR:OPTIONAL
- 1.2 CONTACT:BRASS C2680R/H T=0.20MM
- 1.3 SHELL: BRASS C2680R/H T=0.50MM
- 1.4 SRPING:STAINLESS STEEL T=0.15MM

2. PLATING:

- 2.1 CONTACT: Au 15u" PLATED ON CONTACT AREA
- △ 80u" MATTE TIN PLATED ON SOLDER TAIL
- 50u" NICKEL UNDER-PLATED

2.2 SHELL:50u" NICKEL PLATED OVERALL

3. CHARACTERISTICS:

- 3.1 ELECTRICAL CHARACTERISTICS;
- CONTACT RESISTANCE:30mΩ MAXIMUM
- CONTACT CURRENT RATING:0.5A
- DIELECTRIC WITHSTANDING VOLTAGE:500 V R.M.S.
- INSULATION RESISTANCE 100 MEGOHMS MIN
- OPERATING TEMPERATURE:-25°C ~ +85°C

3.2 MECHANICAL:

- MATING FORCE: 4.5kgf MAX.
- UNMATING FORCE: 1.0~4.0Kg.
- DURABILITY TEST: 10000 CYCLES.

4. THE DIMENSIONS WITH"▽"MARK ARE CRITICAL AND SHOULD BE CONTROLLED BY QC.

SOLDER AREA

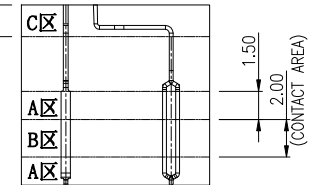

端子整体镀镍底50u"

A 区镀金: Gold flash

B 区镀金: Au 15u".

C 区镀锡: 80u"

图号 (DWG NO)	G-306-S1-568	单位 (UNIT): MM	<b>显赫电子科技有限公司</b> XianHe Electronic Technology co., Ltd.	
类别 (DWG TYPE)	SALES DWG	比例 (SCALE): 1:1		
版次 (REV): A/2	页次 (PAGE): 1/1		TEL:0769-89138899 FAX:0769-89100950	
设计 (DESIGN)	Allen_Tsai	未注公差 TOLERANCE UNSPECIFIED	品名 (ITEM NO)	HDMI 2.1 A TYPE REC SMT H=6.20MM 无后盖 顶部加弹片
审核 (CHECKED)		.X.X ± 0.38 .X.XX ± 0.20 .X.XXX ± 0.10 " ± 5° X.X' ± 2'	料号 (PART NO)	30619FK5CP3HF
核准 (APPROVED)				