

RoHS Compliant

REV.	ECN NO	LTR	DESCRIPTION	REVISER	DATE
A/0			Initial_release.	JN	2021.05.06

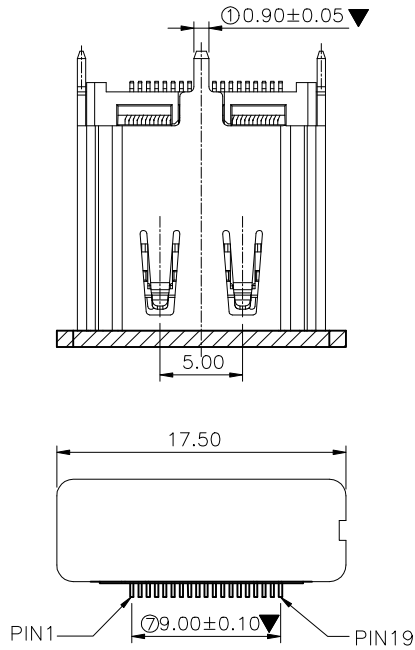

- NOTE:
- MATERIAL:
    - INSULATOR:LCP, UL94V-0, COLOR:BLACK
    - CONTACT:BRASS C2680, T=0.20MM
    - SHELL:BRASS C2680, T=0.50MM
  - PLATING:
    - CONTACT:GOLD G/F PLATED ON CONTACT AREA  
GOLD G/F PLATING OF WELDING TAIL  
50u" Min. NICKEL UNDER-PLATED
    - SHELL:50u" Min. NICKEL PLATED OVERALL
  - CHARACTERISTICS:
    - ELECTRICAL CHARACTERISTICS:
      - RATING CURRENT: 0.5A
      - RATING VOLTAGE: 40V
      - CONTACT RESISTANCE: 10 MILLIOHMS MAX (EXCLUDING CONDUCTOR RESISTANCE)
      - INSULATION RESISTANCE:  
UNMATED: 100M OHMS MIN AT 500 VDC  
MATED: 10M OHMS MIN AT 150 VDC
      - DIELECTRIC WITHSTANDING VOLTAGE: 300V AC/1MINUTE
      - OPERATING TEMPERATURE: -20°C--+85°C
      - STORAGE TEMPERATURE: -20°C--+65°C
    - MECHANICAL:
      - MATING FORCE: 44.1N.Max.
      - UNMATING FORCE: 9.8N~39.2N.
      - DURABILITY TEST: 10000 CYCLES.

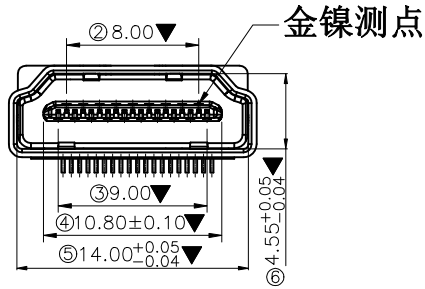
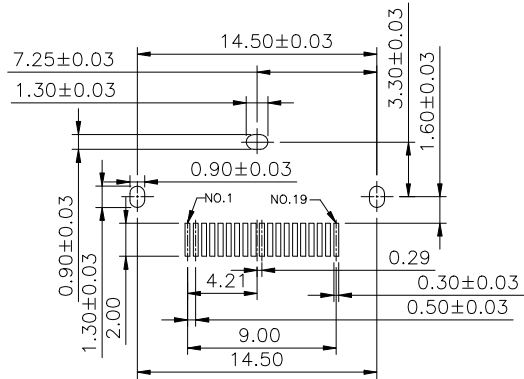

RECOMMENDED PCB LAYOUT( T=1.60mm)  
TOP VIEW

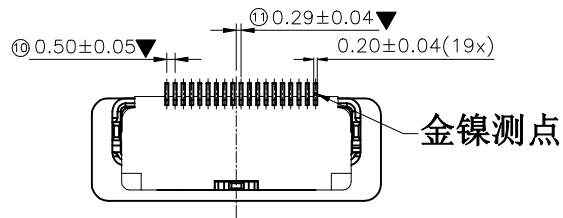
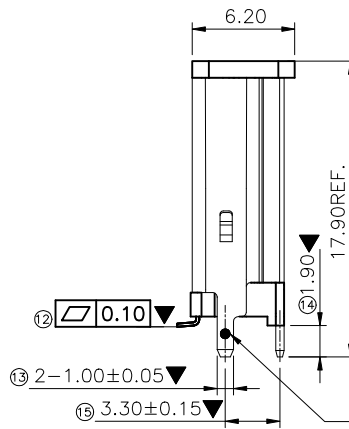
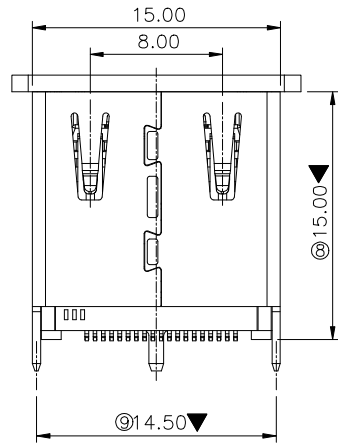

图号 (DWG NO)	G-319-S1-534	单位 (UNIT):	MM	<b>显赫电子科技有限公司</b> XianHe Electronic Technology co., ltd.	
类别 (DWG TYPE)	BRKE DWG	比例 (SCALE):	1:1		
版次 (REV):	A/0	页次 (PAGE):	1/1	TEL:0769-89138899 FAX:0769-89100950	
设计 (DESIGN)	JN	未注公差	TOLERANCE UNSPECIFIED	品名 (ITEM NO)	HDMI A TYPE REC.180度立式SMT H=15.0mm/DIP脚长1.9mm, 加CAP,LCP黑色 镀金G/F, 铜壳镀镍, 卷带包装 无卤
审核 (CHECKED)		.X.X	± 0.38	料号 (PART NO)	30619FK1CP4HF
核准 (APPROVED)		.X.XX	± 0.20		
		.X.XXX	± 0.10		
		X'	± 5'		
		X'X'	± 2'		