

RoHS Compliant

REV.	ECN NO	LTR	DESCRIPTION	REVISER	DATE
A/0			Initial release.	Nelson	2010.12.22

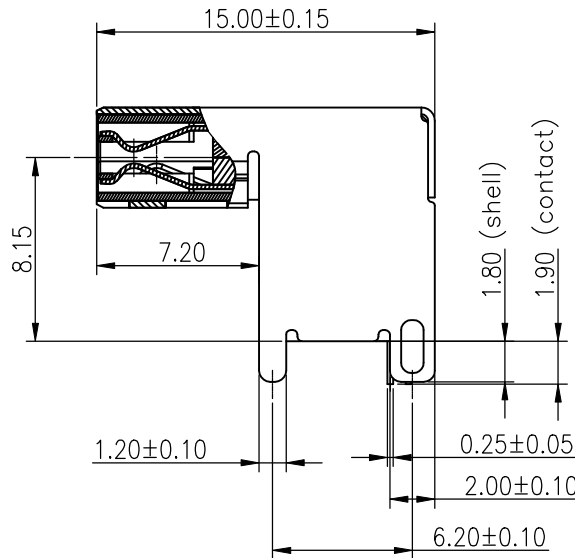
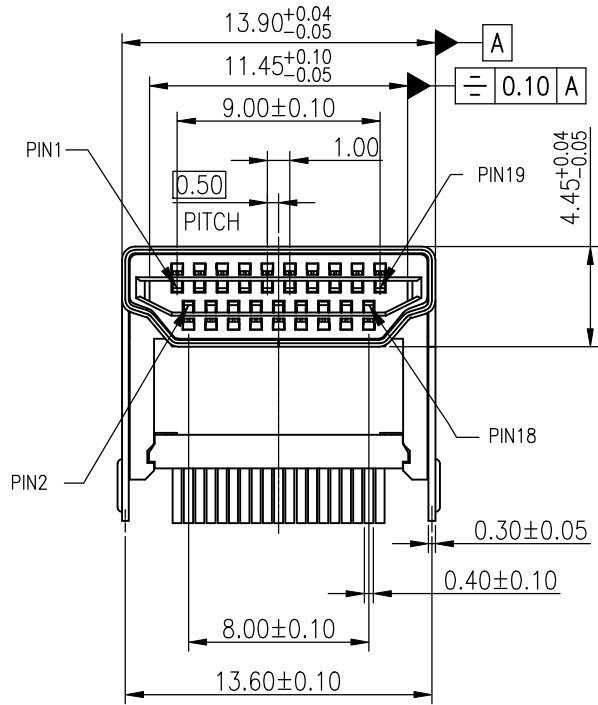

NOTE:

1. MATERIAL:

- 1.1 INSULATOR: LCP+30%GF, UL94V-0, COLOR: BLACK
- 1.2 COVER: LCP+30%GF, UL94V-0, COLOR: BLACK
- 1.3 CONTACT: C5191R/H
- 1.4 SHELL: BRASS

2. PLATING:

- 2.1 CONTACT: SELECTIVE GOLD PLATED ON CONTACT AREA
100u" Min. TIN PLATED ON SOLDER TAIL
50u" Min. NICKEL UNDER-PLATED
- 2.2 SHELL: 50u" Min. NICKEL PLATED OVERALL

3. CHARACTERISTICS:

- 3.1 ELECTRICAL CHARACTERISTICS;
CONTACT RESISTANCE: 30mΩ MAXIMUM
CONTACT CURRENT RATING: 0.5A
DIELECTRIC WITHSTANDING VOLTAGE: 500 V R.M.S.
INSULATION RESISTANCE 100 MEGOHMS MIN
OPERATING TEMPERATURE: -25°C ~ +85°C
- 3.2 MECHANICAL:
MATING FORCE: 4.5Kgf. Max.
UNMATING FORCE: 1.0~4.0Kgf.

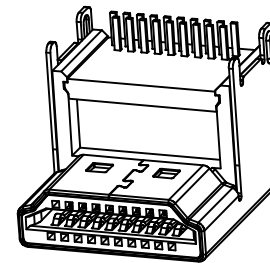
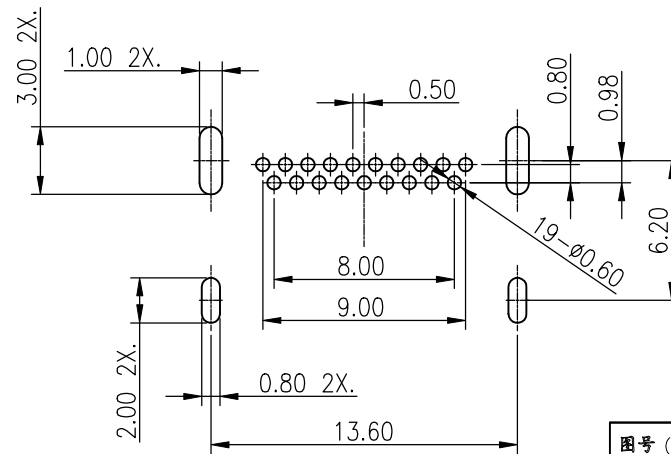
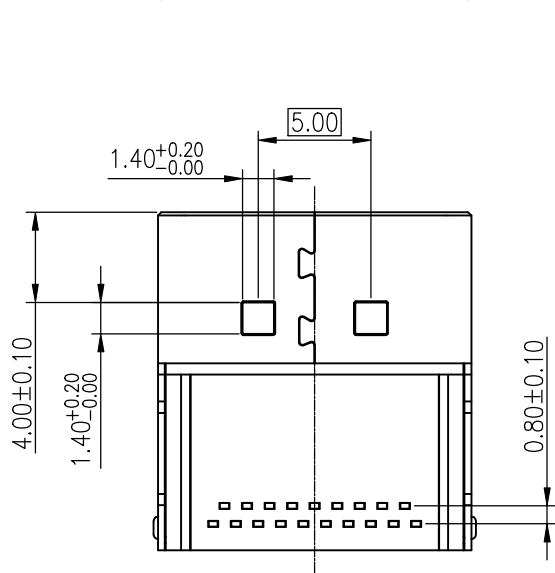

Table:

Gold 3u" plated on contact area, 100u" Min. sn plated on solder area, 50u" Min. Nickel underplated all over	30619MK2CA4
Gold 30u" plated on contact area, 100u" Min. sn plated on solder area, 50u" Min. Nickel underplated all over	30619MK12CA1
Gold 15u" plated on contact area, 100u" Min. sn plated on solder area, 50u" Min. Nickel underplated all over	30619MK11CA1
Plating Descriptions	Part No.

图号 (DWG NO)	G-306-S1-23	单位 (UNIT):	MM	显赫电子科技有限公司 XianHe Electronic Technology co., Ltd. TEL: 0769-89138899 FAX: 0769-89100950
类别 (DWG TYPE)	SALES DWG	比例 (SCALE)	1:1	
版次 (REV):	A/0	页次 (PAGE):	1/1	品名 (ITEM NO) HDMI A PLUG DIP R/A 料号 (PART NO) See Table
设计 (DESIGN)	Nelson	未注公差	TOLERANCE UNSPECIFIED X.X ± 0.38 X.XX ± 0.20 X.XXX ± 0.10 X" ± 5 X.X" ± 2	
审核 (CHECKED)				
核准 (APPROVED)				