

RoHS Compliant

REV.	ECN NO	LTR	DESCRIPTION	REVISER	DATE
A/0			Initial release.	Jerry	2017.05.24
A/1		△	增加SMT脚尺寸定义	Joe peng	2017.06.26
A/2	20200525001	△	重新定义品名描述	Joe peng	2020.05.25

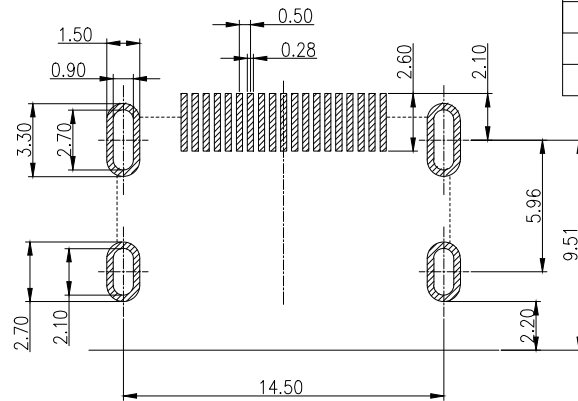
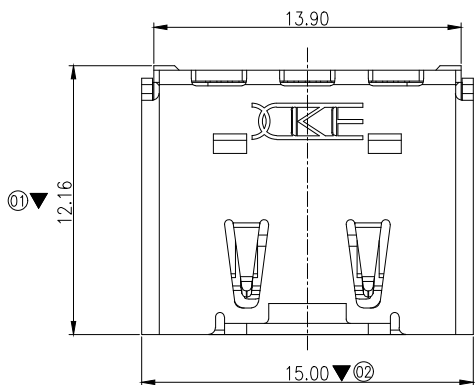

RECOMMENDED PCB LAYOUT  
TOP VIEW, THICKNESS :1.6mm

NOTE:

1. MATERIAL:

- 1.1 INSULATOR:LCP+30%GF, UL94V-0, COLOR:BLACK
- 1.2 CONTACT:COPPER ALLOY
- 1.3 SHELL:COPPER ALLOY

2. PLATING:

- 2.1 CONTACT: Gold 15u" PLATED ON CONTACT AREA  
100u" Min. TIN PLATED ON SOLDER TAIL  
50u" Min. NICKEL UNDER-PLATED
- 2.2 SHELL:50u" Min. NICKEL PLATED OVERALL

3. CHARACTERISTICS:

- 3.1 ELECTRICAL CHARACTERISTICS;  
CONTACT RESISTANCE:30mΩ MAXIMUM  
CONTACT CURRENT RATING:0.5A  
DIELECTRIC WITHSTANDING VOLTAGE:500 V R.M.S.  
INSULATION RESISTANCE 100 MEGOHMS MIN  
OPERATING TEMPERATURE:-25°C ~ +85°C
- 3.2 MECHANICAL:  
MATING FORCE: 4.5Kg.Max.  
UNMATING FORCE: 1.0~4.0Kg.Min.

- 5. THE DIMENSIONS WITH "▼" MARK ARE CRITICAL AND SHOULD BE CONTROLLED BY QC.

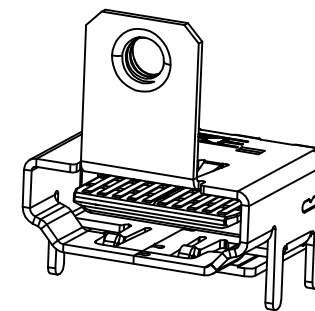
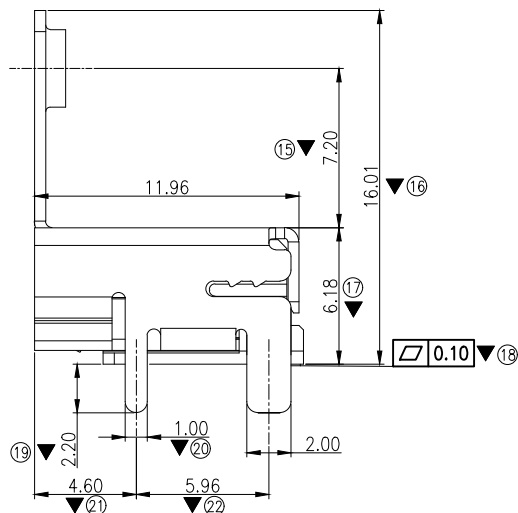
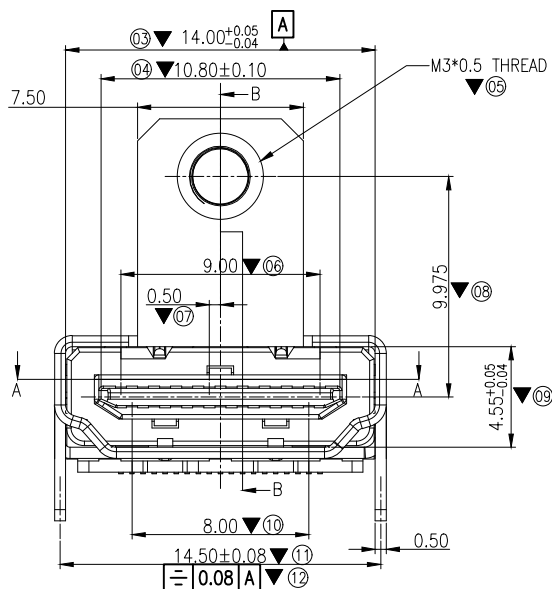

3D VIEWS

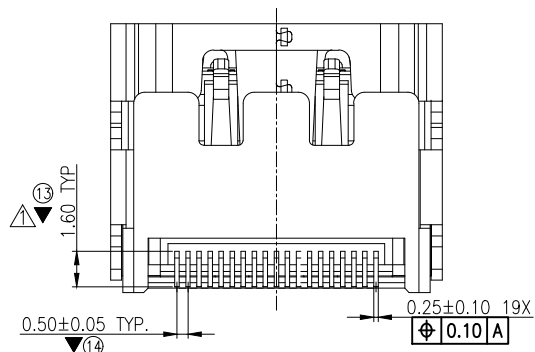

图号 (DWG NO)	G-306-S1-74	单位 (UNIT):	MM	<b>显赫电子科技有限公司</b> XianHe Electronic Technology co., Ltd.
类别 (DWG TYPE)	SALES DWG	比例 (SCALE)	1:1	
版次 (REV):	A/2	页次 (PAGE):	1/1	TEL:0769-89138899 FAX:0769-89100950
设计 (DESIGN)	Jerry	未注公差	TOLERANCE UNSPECIFIED	品名 (ITEM NO) △ HDMI 2.1 A type rec. 外壳DIP式 SMT 带法兰 有显赫LOGO
审核 (CHECKED)		X.X ± 0.38	X.XX ± 0.20	
核准 (APPROVED)		X.XXX ± 0.10	X' ± 5'	料号 (PART NO)
		X.X' ± 2'		30619MK5CA2