

RoHS Compliant

REV.	ECN NO	LTR	DESCRIPTION	REVISER	DATE
A/0			Initial release.	WJR	2013.06.08

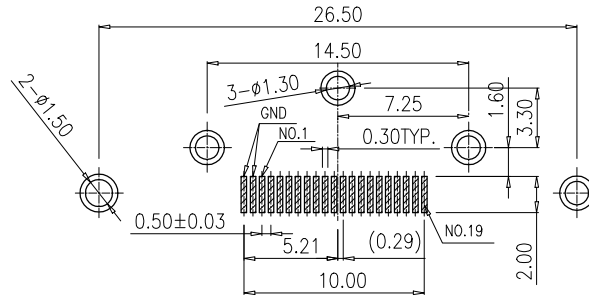

RECOMMENDED PCB LAYOUT
TOP VIEW, TOLERANCE:±0.05

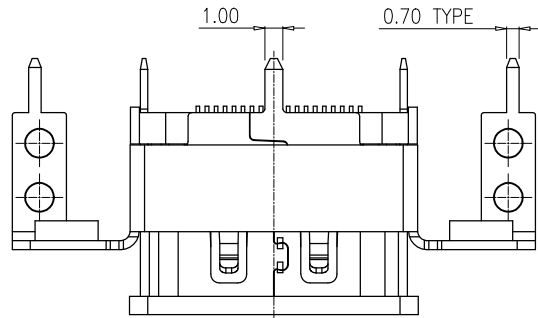
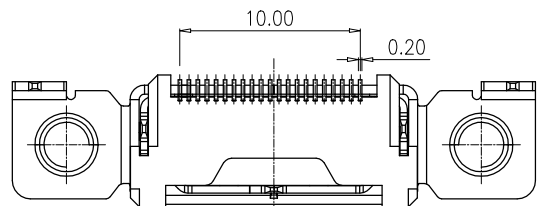
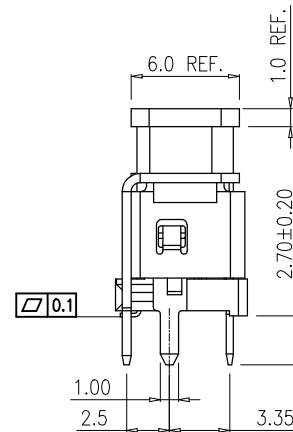
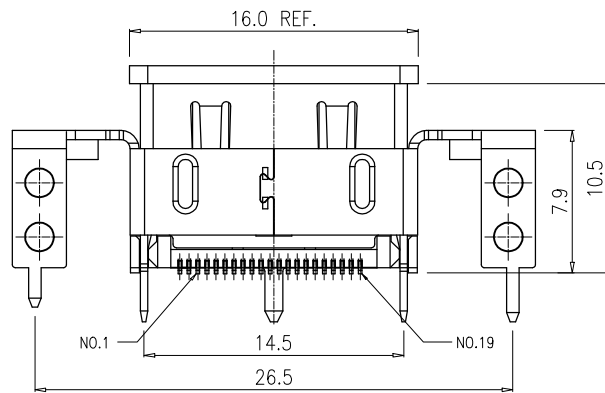
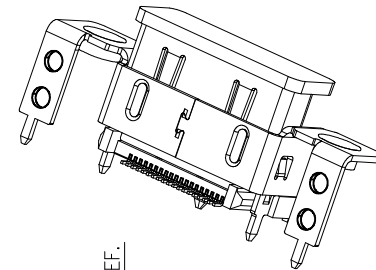
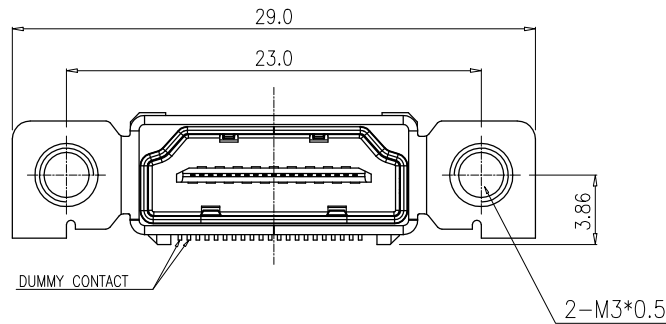

NOTE:

1. MATERIAL:

- 1.1 INSULATOR:LCP+30%GF, UL94V-0, COLOR:BLACK
- 1.2 CAP:LCP+30%GF, UL94V-0, COLOR:BLACK
- 1.3 CONTACT: C2680R/H
- 1.4 SHELL:BRASS
- 1.5 BRACKET: STEEL

2. PLATING:

- 2.1 CONTACT: SELECTIVE GOLD PLATED ON CONTACT AREA 100u" Min. MATTE TIN PLATED ON SOLDER TAIL 50u" Min. NICKEL UNDER-PLATED
- 2.2 SHELL:50u" Min. NICKEL PLATED OVERALL
- 2.3 BRACKET:50u" Min. NICKEL PLATED OVERALL

3. CHARACTERISTICS:

- 3.1 ELECTRICAL CHARACTERISTICS;
CONTACT RESISTANCE:30mΩ MAXIMUM
CONTACT CURRENT RATING:0.5A
DIELECTRIC WITHSTANDING VOLTAGE:500 V R.M.S.
INSULATION RESISTANCE 100 MEGOHMS MIN
OPERATING TEMPERATURE:-25°C ~ +85°C

3.2 MECHANICAL:

- MATING FORCE:4.5Kgf MAX.
- UNMATING FORCE:1.0~4.0 Kgf

PART NUMBER INFORMATION

30619FK-X-C-C1-HF

HF: Halogen Free
BLANK: RoHS

Terminal plating:

- 1: Gold 1u" on contact area.
- 3: Gold 5u" on contact area.
- 4: Gold 15u" on contact area.
- 6: Gold 30u" on contact area.

图号 (DWG NO)	G-331-S1-33	单位 (UNIT): MM	显赫电子科技有限公司 XianHe Electronic Technology co., Ltd.
类别 (DWG TYPE)	SALES DWG	比例 (SCALE) 1:1	
版次 (REV): A/0	页次 (PAGE): 1/1		TEL:0769-89138899 FAX:0769-89100950
设计 (DESIGN)	WJR	未注公差 TOLERANCE UNSPECIFIED	品名 (ITEM NO)
审核 (CHECKED)		.X.X ± 0.38 .X.XX ± 0.20 .X.XXX ± 0.10 X ± 5 X.X ± 2	HDMI A TYPE REC. VERTICAL SMT WITH CAP/WITH BRACKET/21PIN
核准 (APPROVED)			料号 (PART NO)
			30619FKXCC1HF