

RoHS Compliant

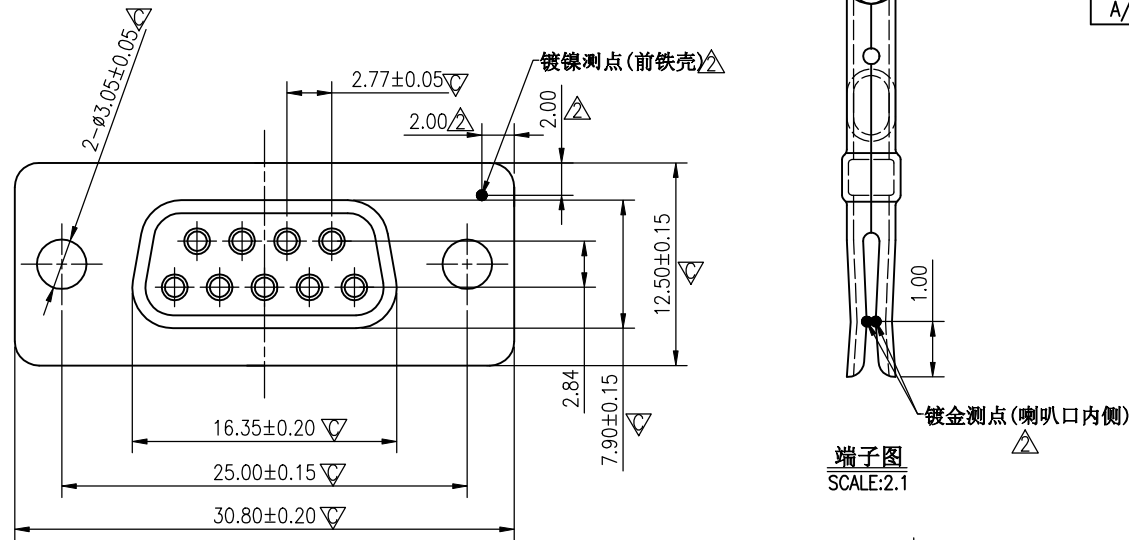

端子图
SCALE:2.1

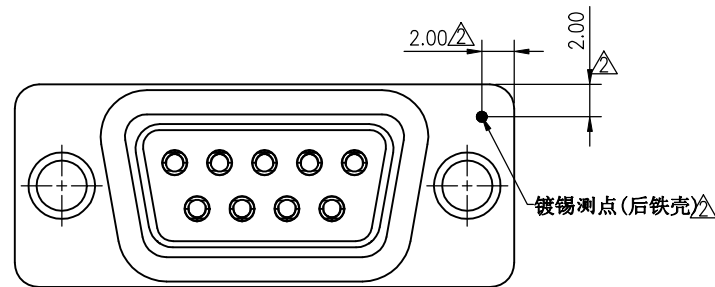
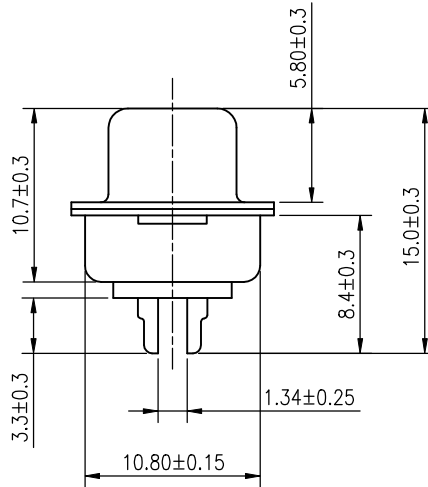
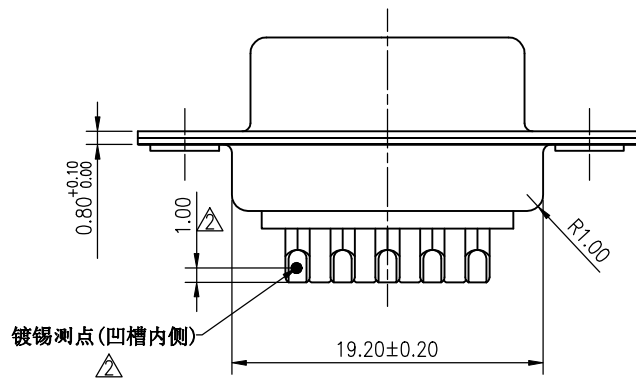

REV.	ECN NO	LTR	DESCRIPTION	REVISER	DATE
A/0			Initial release.	XINBIYING	2004.05.17
A/1	20121203002	△	增加插拔力标准/盐雾标准	Wang_jr	2012.12.03
A/2		△	增加膜厚测试点	Joe.peng	2018.03.26

NOTE:

1. MATERIAL:

- 1.1 INSULATOR:PBT+30%GF, UL94V-0, COLOR:OPTIONAL
- 1.2 CONTACT:C2680
- 1.3 SHELL:SPCC-SD

2. PLATING:

- 2.1 CONTACT: SELECTIVE GOLD PLATED ON CONTACT AREA
80u" Min. TIN PLATED ON SOLDER TAIL
50u" Min. NICKEL UNDER-PLATED
- 2.2 SHELL:
FRONT SHELL:80U"MIN. NICKEL PLATING OVER 60U"MIN.CU.
BACK SHELL:80U"MIN. TIN PLATING OVER 60U"MIN.CU.

3. CHARACTERISTICS:

- 3.1 ELECTRICAL CHARACTERISTICS:
CONTACT RESISTANCE:30mΩ MAXIMUM
CONTACT CURRENT RATING:3A
DIELECTRIC WITHSTANDING VOLTAGE:500 V R.M.S.
INSULATION RESISTANCE 5000 MEGOHMS MIN
OPERATING TEMPERATURE:-55°C ~ +105°C

△ 3.2 MECHANICAL:

- MATING FORCE: 3.06Kg.Max.
- UNMATING FORCE: 0.33Kg~2.04kg
- DURABILITY:3000 CYCLES AT A RATE OF 250 CYCLES PER HOUR.

△ 4. SALT SPRAY TEST:NIKEL PLATING 16H MIN;TIN PLATING 8H;GOLD PLATING 24H MIN

5. ROHS COMPLIANT.

PART NUMBER INFORMATION
30109F-X-X-2-X-X-XX

Hsg.color:
B:Blue
K:Black
W:White

HF:HALOGEN FREE
BLANK:ROHS

Plating option:

- 1:Gold flash
- 2:Selective gold 3u" plating
- 3:Selective gold 5u" plating
- 4:Selective gold 10u" plating
- 5:Selective gold 15u" plating
- 6:Selective gold 30u" plating

Shell plating option:

- A:Salt spray 12H
- C:Salt spray 24H
- D:Salt spray 48H
- E:Front shell gold plating

Rivet option:

- A:Rivet solid nut on front
- B:Rivet hollow nut on back
- C:Rivet hollow nut on front
- X:No rivets
- A1:Ass'y solid nut on front
the nuts are gold plating
- A2:ass'y hollow nut on back
ass'y the screw on conn.
- B1:Ass'y hollow nut on back
the nuts are rotundity
- B3:ass'y hollow nut on back
the nut high 2.5mm

图号 (DWG NO)	G-301-S1-13	单位 (UNIT): MM		显赫电子科技有限公司 XianHe Electronic Technology co., Ltd.	
类别 (DWG TYPE)	SALES DWG	比例 (SCALE) 1:1			
版次 (REV): A/2	页次 (PAGE): 1/1		TEL:0769-89138899 FAX:0769-89100950		
设计 (DESIGN)	Xinbiying	未注公差 TOLERANCE UNSPECIFIED X.X ± 0.38 X.XX ± 0.20 X.XXX ± 0.10 * ± 5 X.X ± 2	品名 (ITEM NO)	DB-9Pin 母 传统焊线式	
审核 (CHECKED)			料号 (PART NO)	Please see P/N information	
核准 (APPROVED)					