

RoHS Compliant

REV.	ECN NO	LTR	DESCRIPTION	REVISER	DATE
A/0			Initial_release.	DWZ	2014.06.16
A/1		▲	Add a critical diminsion; modify tolerance	NELSON	2017.02.17
A/2		▲	变更螺母口部倒角为C0.2mm	HCZ	2020.11.25

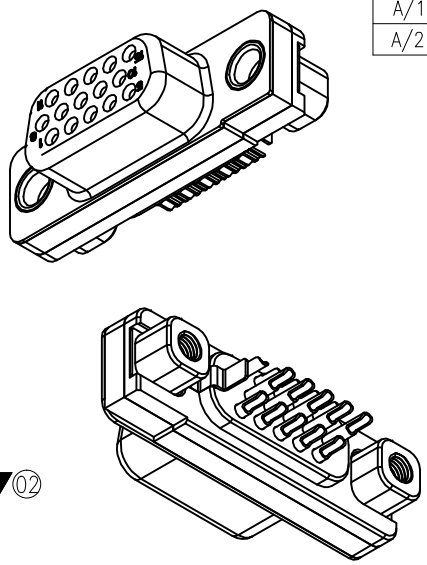

- NOTE:
- MATERIAL:
 - INSULATOR:PBT+30%GF, UL94V-0, COLOR:Black
 - CONTACT: Copper alloy,T=0.2
 - SHELL:SPCC, T=0.35mm,
 - PLATING:
 - CONTACT: GOLD 30u" PLATED ON CONTACT AREA
100u" Min. TIN PLATED ON SOLDER TAIL
50u" Min. NICKEL UNDER-PLATED
 - SHELL:50u" Min. NICKEL PLATED OVERALL
 - CHARACTERISTICS:
 - Contact Current Rating:5 AMPS
Insulation Resistance:1000M Ohm MIN. AT 500V DC
Dielectric Withstanding Volt:AC 500V/min.R.M.S.
Operation Temperature:-55°C ~ +105°C
Screw recede and twist force: 2.5Kgf Min.
 - MECHANICAL:
MATING FORCE: 5.1Kg.Max.
UNMATING FORCE: 1-4.0Kg.
 - THE DIMENSIONS WITH "▼" MARK ARE CRITICAL AND SHOULD BE CONTROLLED BY QC.

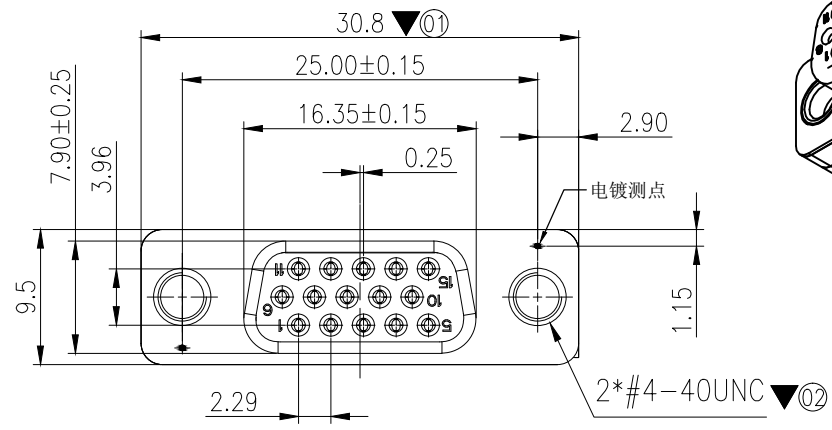
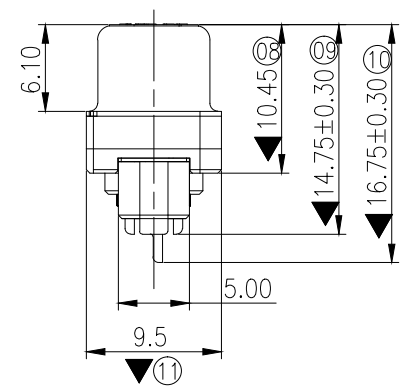
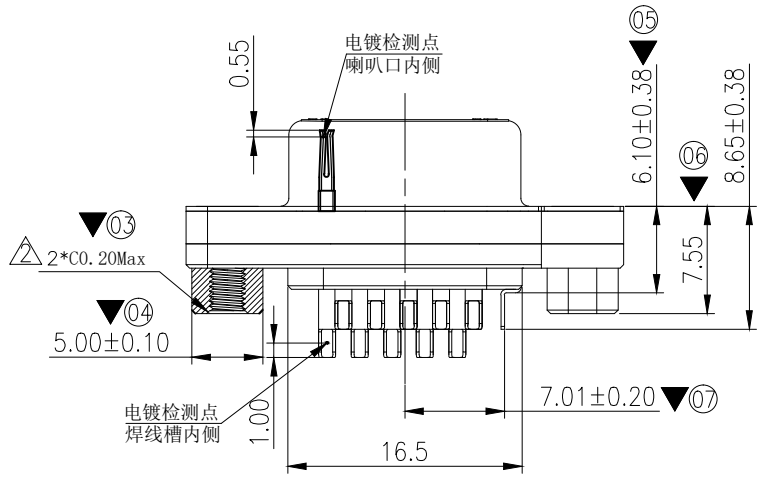

PART NUMBER INFORMATION:
30315F-X-X-2AXAB-AX-HF

Housing color:
B:blue
K:black

Terminal plating: _____

HALOGEN FREE

Ter.material & Gap option.
A0:Brass & with Gap
A1:Brass & without Gap

- Gold flash on contact area.
100u" Min tin plating on solder tail.
- Gold 15u" Min. on contact area.
100u" Min tin plating on solder tail.
- Gold 30u" Min. on contact area.
100u" Min tin plating on solder tail.

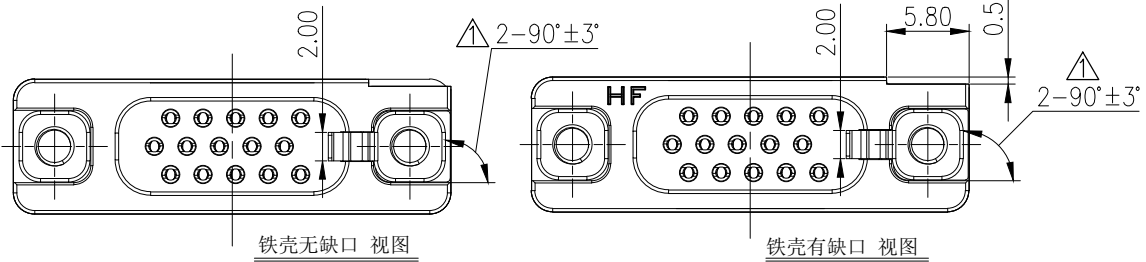

图号 (DWG NO)	G-303-S1-44	单位 (UNIT):	MM	显赫电子科技有限公司 XianHe Electronic Technology co., ,ltd.
类别 (DWG TYPE)	SALES DWG	比例 (SCALE)	1:1	
版次 (REV):	A/2	页次 (PAGE):	1/1	TEL:0769-89138899 FAX:0769-89100950
设计 (DESIGN)	DENGWEIZHI	未注公差	TOLERANCE UNSPECIFIED	品名 (ITEM NO) D-sub 15Pin 母 180度焊线式 不切角后脚四方空芯螺母
审核 (CHECKED)		X.X ± 0.38 X.XX ± 0.20 X.XXX ± 0.10 X' ± 5' X.X' ± 2'		
核准 (APPROVED)				料号 (PART NO) Please see P/N information