

RoHS Compliant

REV.	ECN NO	LTR	DESCRIPTION	REVISER	DATE
A/1		⚠	连接器与PCB板之间增加支撑板, 加大产品强度.	WB	2020.05.16
A/2	20210929001	⚠	焊点数量由6个增加到12个, 增加内壳与外壳之间的强度.	WB	2021.08.16
A/3		⚠	新增15U" 规格料号.	LINA	2023.02.17

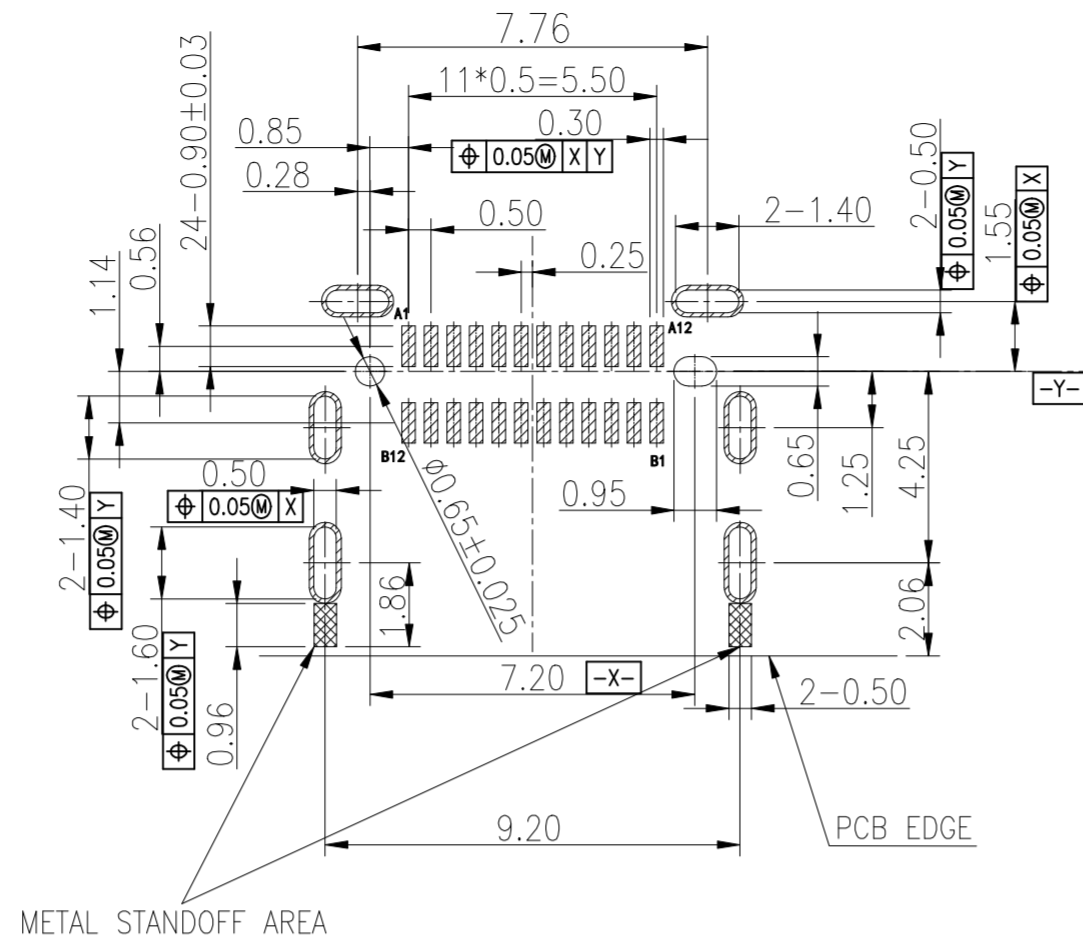

RECOMMENDED P.C.B LAYOUT (COMPONENT SIDE)
TOLERANCE: ±0.05

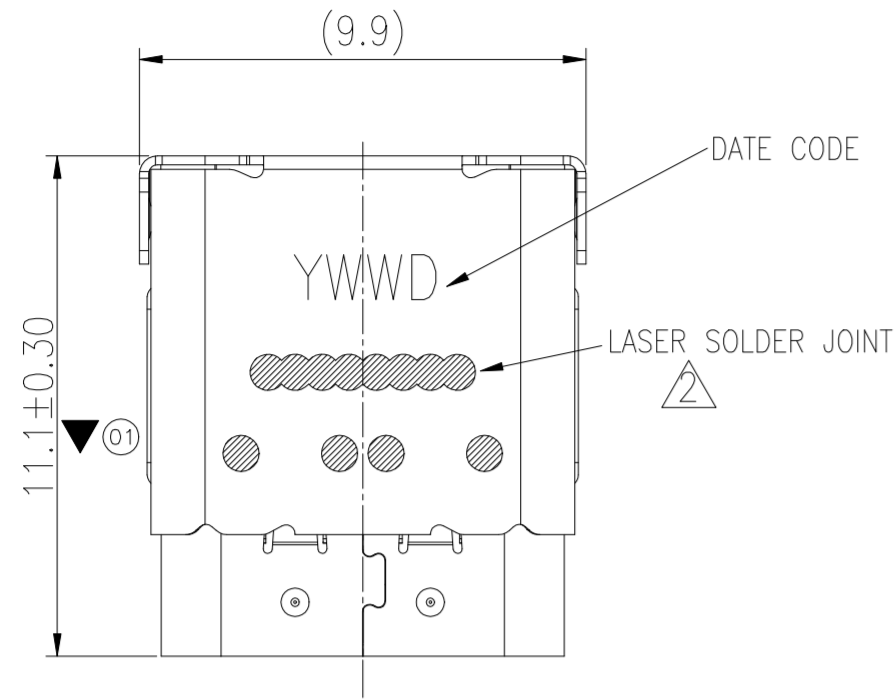
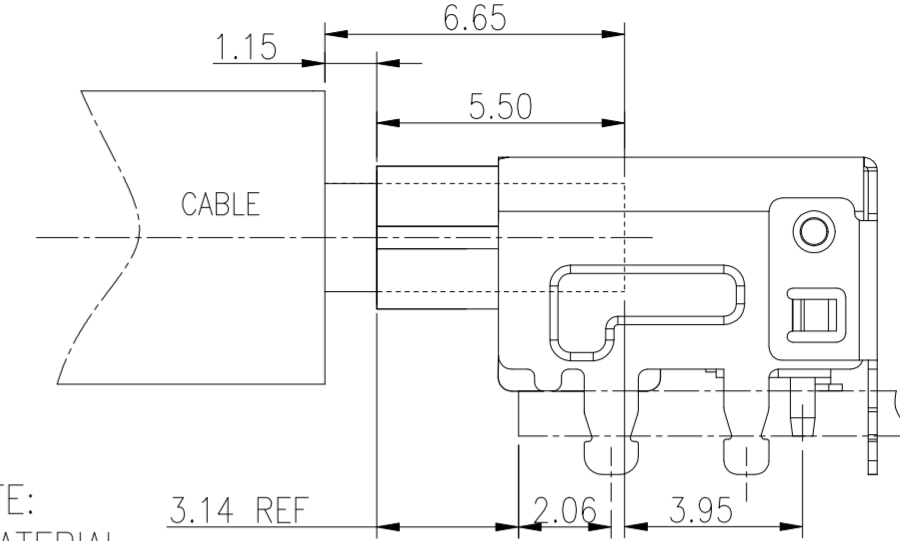

- NOTE:
1. MATERIAL:
1.1 HOUSING: LCP E130i; UL94V-0, COLOR: BLACK
1.2 TERMINAL: HIGH CONDUCTIVE COPPER C18400 T=0.15MM
1.3 SHELL: STAINLESS STEEL SUS304 T=0.30MM
1.4 OUTER SHIELD: STAINLESS STEEL SUS304 T=0.20MM
1.5 LATCH: STAINLESS STEEL SUS304 T=0.15MM
1.6 EMI_SPRING: STAINLESS STEEL SUS304 T=0.10MM
1.7 SUPPORT PLATE: SUS304 T=0.3MM
2. PLATING:
2.1 CONTACT: SELECTIVE GOLD PLATED ON CONTACT AREA
GOLD FLASH PLATED ON SOLDER TAIL
50u" Min. NICKEL UNDER-PLATED
2.2 SHELL: 50u" Min. NICKEL PLATED OVERALL
2.3 OUTER SHIELD: NICKEL PLATING 50 u" MINIMUM OVERALL
2.4 LATCH AND EMI SPRING: CLEAN
2.5 SUPPORT PLATE: CLEAN
3. CHARACTERISTICS:
3.1 ELECTRICAL CHARACTERISTICS:
CONTACT RESISTANCE: 40mΩ MAXIMUM
CONTACT CURRENT RATING: 5A Max FOR VBUS; 1.25A FOR OTHER PIN
DIELECTRIC WITHSTANDING VOLTAGE: 100 V R.M.S.
INSULATION RESISTANCE: 100 MEGOHMS MIN
OPERATING TEMPERATURE: -40°C ~ +80°C
3.2 MECHANICAL:
MATING FORCE: 5~20N
UNMATING FORCE: 8~20N. AFTER DURABILITY: 6~20N
4. THE DIMENSIONS WITH "▼" MARK ARE CRITICAL AND SHOULD BE CONTROLLED BY QC.

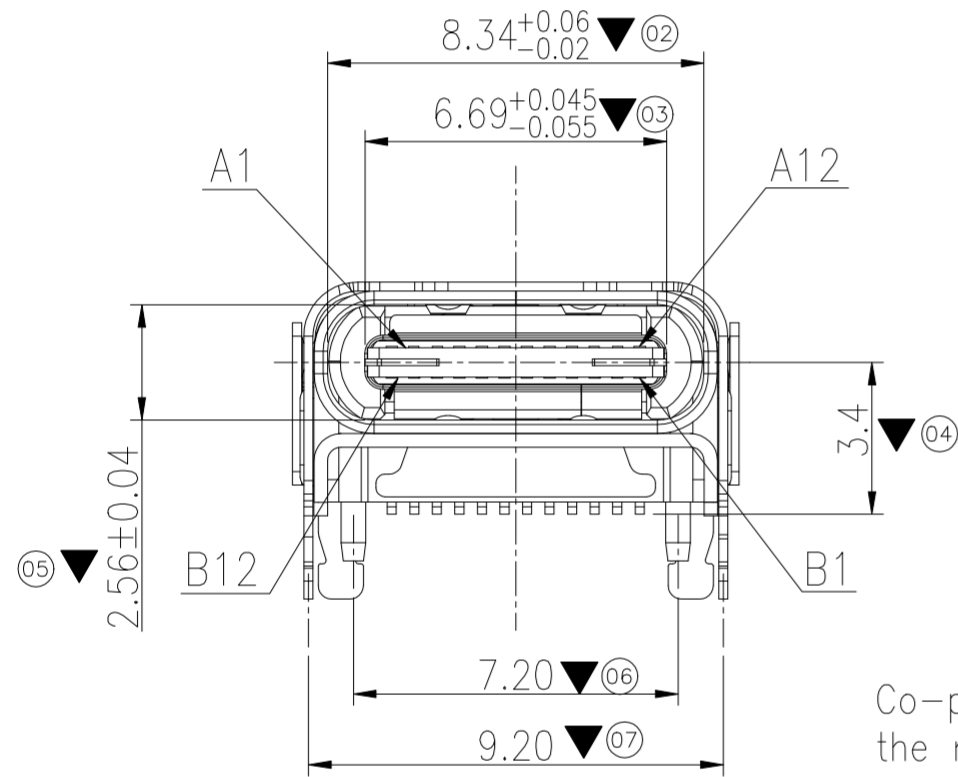

Co-planarity include the metal standoff

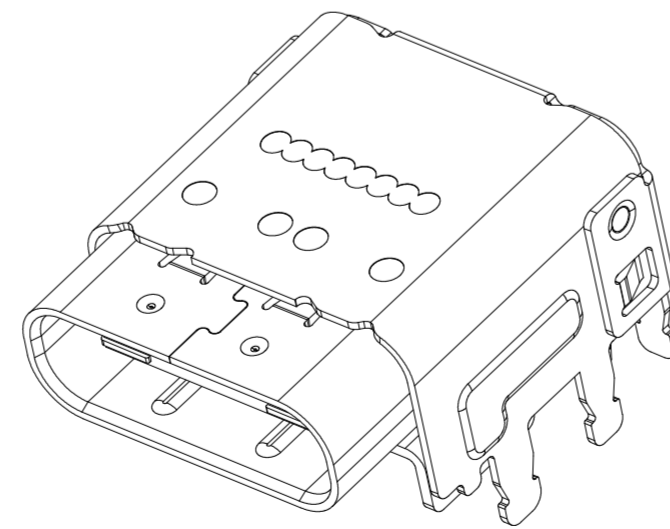
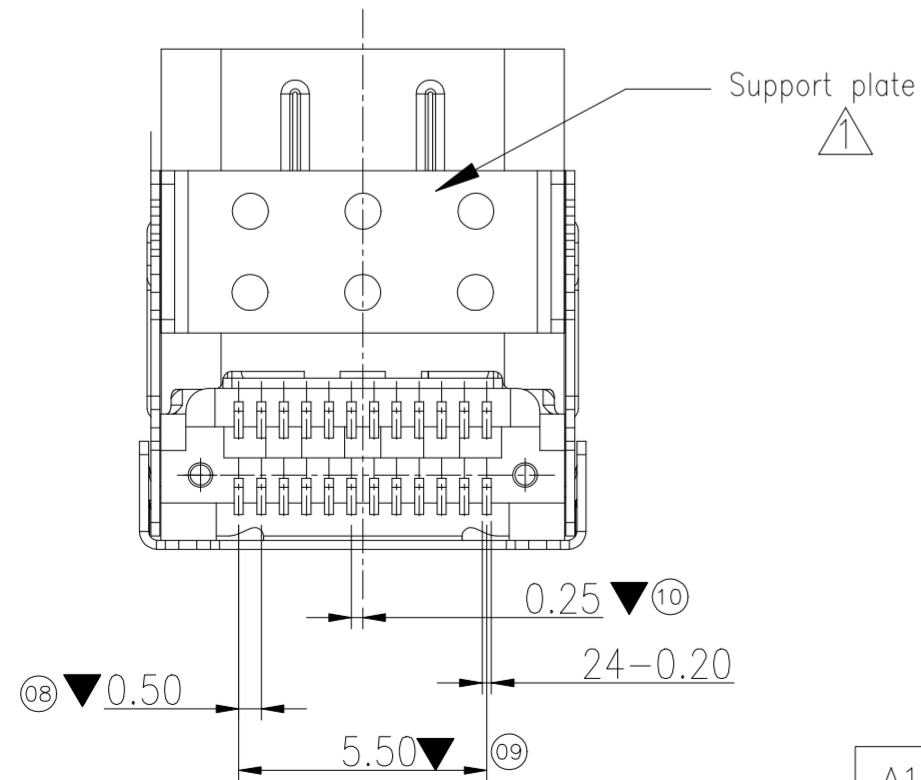
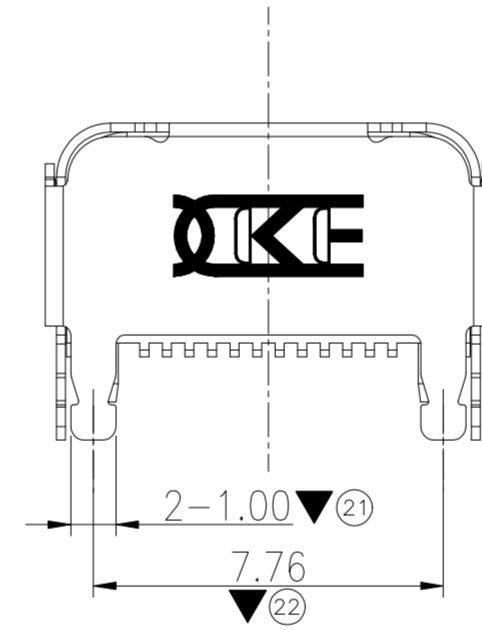
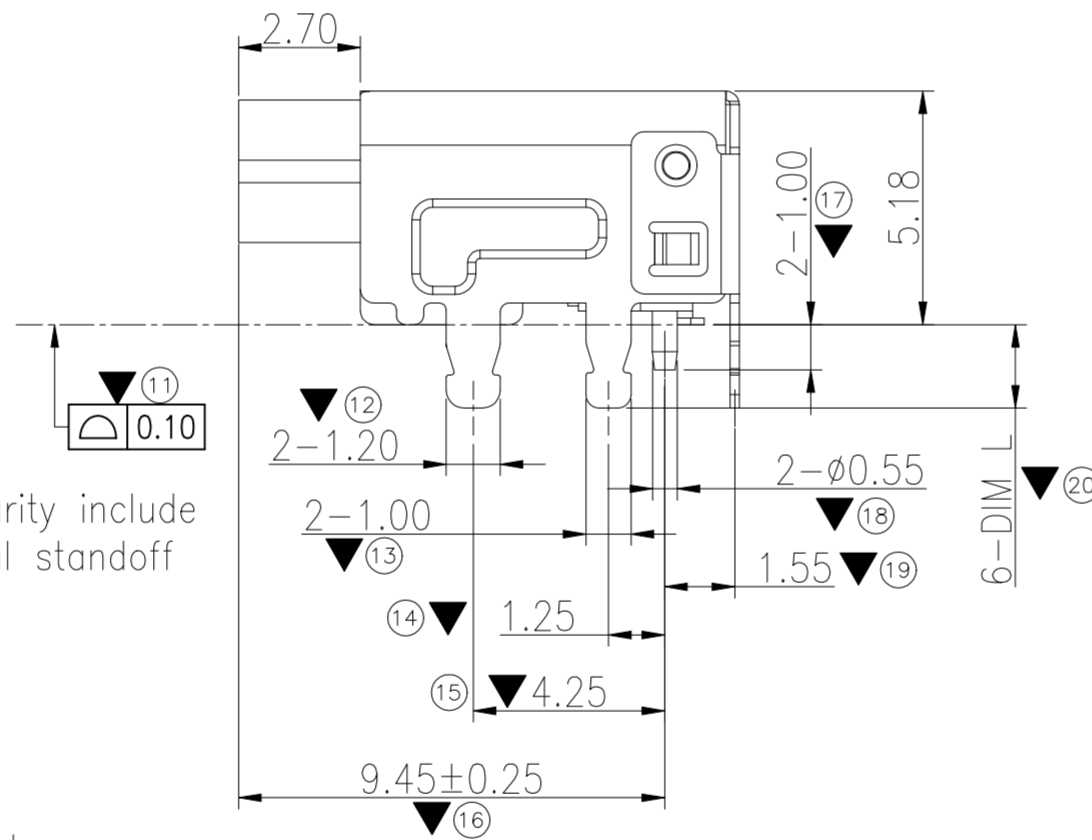

PART NUMBER INFORMATION
319CF-K-XX-X-SN-XX
Hsg. color: _____ HF: Halogen Free
K: Black
Terminal plating:
1: Gold flash
5: Gold 15u" on contact area.
6: Gold 30u" on contact area.

A12	A11	A10	A9	A8	A7	A6	A5	A4	A3	A2	A1
GND	SSRxp2	SSRxn2	Vbus	SBU1	Dn1	Dp1	CC1	Vbus	SSTxn1	SSTxp1	GND
GND	SSTxp2	SSTxn2	Vbus	CC2	Dp2	Dn2	SBU2	Vbus	SSRxn1	SSRxp1	GND
B1	B2	B3	B4	B5	B6	B7	B8	B9	B10	B11	B12

图号 (DWG NO)	G-319-S1-323	单位 (UNIT):	MM
类别 (DWG TYPE)	SALES DWG	比例 (SCALE)	1:1
版次 (REV):	A/3	页次 (PAGE):	1/1
设计 (DESIGN)	Sunny	未注公差	TOLERANCE UNSPECIFIED
审核 (CHECKED)		x.x	± 0.38
核准 (APPROVED)		x.xx	± 0.20
		x.xxx	± 0.10
		x"	± 5'
		x.x"	± 2'



显赫电子科技有限公司

XianHe Electronic Technology co., Ltd.

TEL: 0769-89138899 FAX: 0769-89100950

品名 (ITEM NO)

USB TYPE C REC 2 rows SMT
HIGH RISE, CH=3.4mm/flangeless

料号 (PART NO)

Please see P/N information