

RoHS Compliant

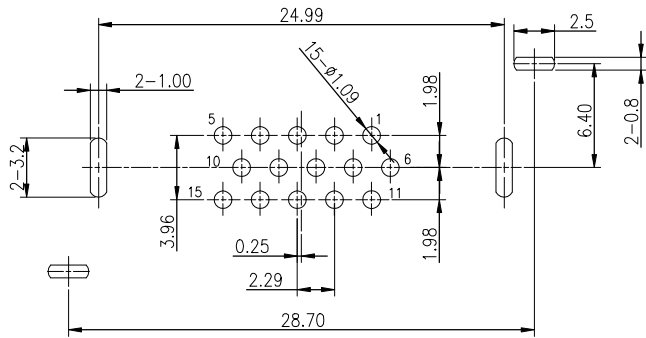
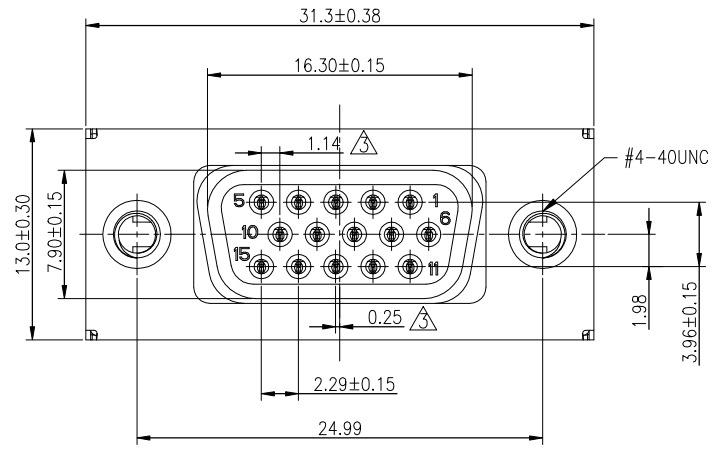

RECOMMENDED P.C.B LAYOUT(TOP VIEW)

P.C.B THICKNESS:1.60±0.10mm.
TOLERANCE:±0.05mm

NOTE:

1. MATERIAL:

- 1.1 INSULATOR:PBT+30%GF, UL94V-0, COLOR:OPTIONAL
- 1.2 COVER:PBT+30%GF, UL94V-0, COLOR:OPTIONAL
- 1.3 CONTACT:BRASS
- 1.4 SHIELD:SPCC-SD
- 1.5 SHELL:SPCC-SD
- 1.6 SCREW:FERROALLOY
- 1.7 GROUNDING CLIP:BRASS

2. PLATING:

- 2.1 CONTACT:GOLD G/F PLATED ON CONTACT AREA
100u" Min. TIN PLATED ON SOLDER TAIL
50u" Min. NICKEL UNDER-PLATED
- 2.2 SHELL:50u" Min. NICKEL PLATED OVERALL
- 2.3 SHIELD/GROUNDING CLIP:100u" Min. TIN PLATED OVERALL

3. CHARACTERISTICS:

- 3.1 ELECTRICAL CHARACTERISTICS;
CONTACT RESISTANCE:20mΩ MAXIMUM
CONTACT CURRENT RATING:2A
VOLTAGE RATING: 40V AC
DIELECTRIC WITHSTANDING VOLTAGE:500 V R.M.S.
INSULATION RESISTANCE 5000 MEGOHMS MIN
OPERATING TEMPERATURE:-25°C ~ +85°C.

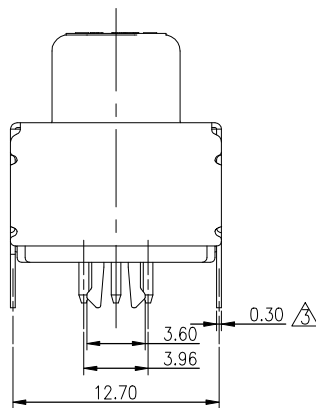
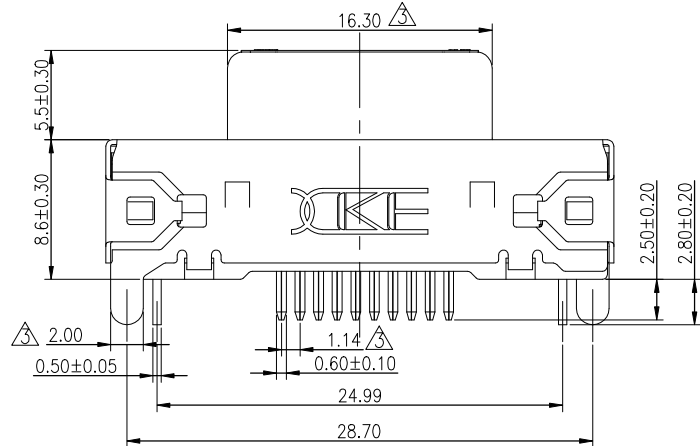

TYPE B:ATTACH SCREW
(附螺丝/铆合)

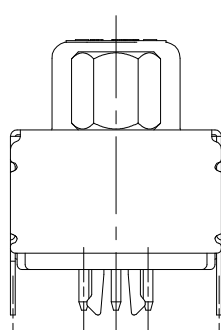
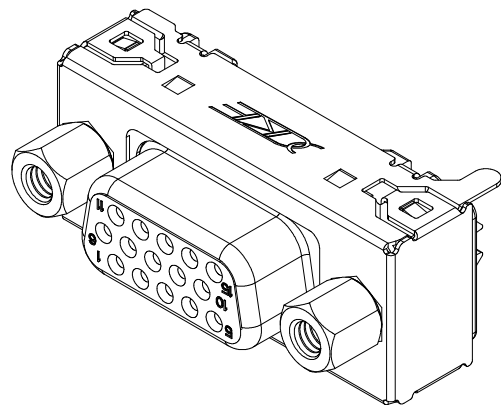
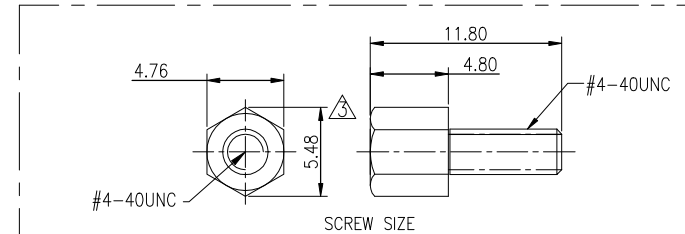

TYPE A:ASS'Y SCREW
(锁螺丝)

6.	31015FB1DYDAOC	D-SUB 15Pin 180度缩9兰色 G/F母座 H=8.5mm 带屏蔽罩有DIP脚 附螺丝(AOC)
5.	31015FB1DYEAO	D-SUB 15Pin 180度缩9兰色 G/F母座 H=8.5mm 带屏蔽罩有DIP脚 锁螺丝(AOC)
4.	31015FB1DYEAC	D-SUB 15Pin 180度缩9兰色 G/F母座 H=8.5mm 带屏蔽罩有DIP脚 锁螺丝(AOC) 自动插件
3.	31015FB1XYEAO	D-SUB 15Pin 180度缩9兰色 G/F母座 H=8.5mm 带屏蔽罩有DIP脚 铆合(AOC)
2.	31015FB1XYEAOCHF	D-SUB 15Pin 180度缩9兰色 G/F母座 H=8.5mm 带屏蔽罩有DIP脚 铆合(AOC) 无齿
1.	31015FK1DYEAO	D-SUB 15Pin 180度缩9黑色 G/F母座 H=8.5mm 带屏蔽罩有DIP脚 锁螺丝(AOC)

ITEM	PART P/N:	PART DESCRIPTION	
图号 (DWG NO)	G-310-S1-22	单位 (UNIT):	MM
类别 (DWG TYPE)	SALES DWG	比例 (SCALE):	1:1
版次 (REV):	A/3	页次 (PAGE):	1/1
设计 (DESIGN)	Evan	未注公差 TOLERANCE UNSPECIFIED	
审核 (CHECKED)		.X.X ± 0.38	
核准 (APPROVED)		.X.XX ± 0.20	
		.X.XXX ± 0.10	
		" ± 5'	
		"X" ± 2'	

显赫电子科技有限公司
XianHe Electronic Technology co., Ltd.

TEL:0769-89138899 FAX:0769-89100950

品名 (ITEM NO) D-SUB 15Pin 180度 缩9Pin 母座 H=8.5mm 带屏蔽罩 有DIP脚 (AOC)

料号 (PART NO) SEE NOTE