

RoHS Compliant

REV.	ECN NO	LTR	DESCRIPTION	REVISER	DATE
A/0			Initial release.	HCZ	2021.09.28

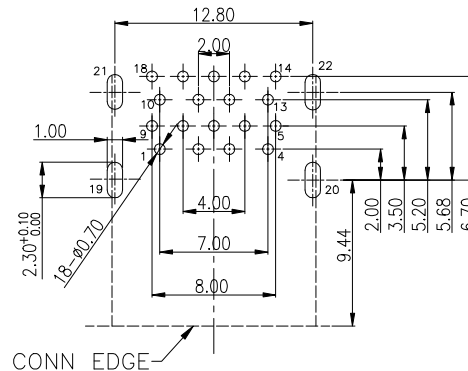
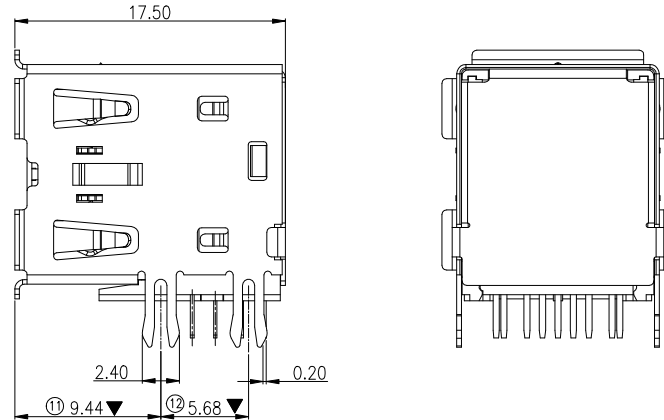
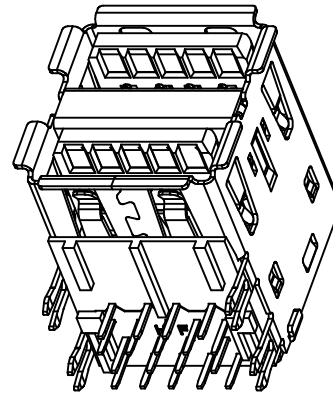
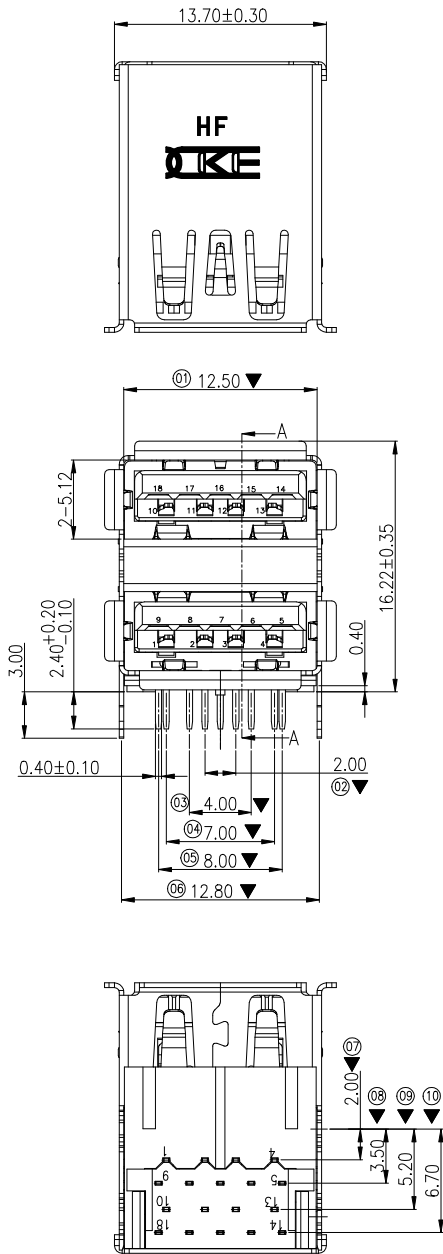

RECOMMENDED PCB LAYOUT  
TOP VIEW, TOL:±0.05MM

NOTE:

1. MATERIAL:

- 1.1 INSULATOR: PA9T+30%GF, UL94V-0, COLOR: BLACK, HF
- 1.2 COVER: PA9T+30%GF, UL94V-0, COLOR: BLACK, HF
- 1.3 CONTACT 2.0: BRONZE
- 1.4 CONTACT 3.0: BRASS
- 1.5 SHELL: COPPER ALLOY
- 1.6 BACK SHELL: COPPER ALLOY
- 1.7 MID SHELL: COPPER ALLOY

2. PLATING:

- 2.1 CONTACT: GOLD 1u" Min PLATED ON CONTACT AREA  
80u" Min. TIN PLATED ON SOLDER TAIL  
50u" Min. NICKEL UNDER-PLATED
- 2.2 SHELL: 50u" Min. NICKEL PLATED OVERALL
- 2.3 BACK SHELL: 50u" Min. NICKEL PLATED OVERALL
- 2.4 MID SHELL: 50u" Min. NICKEL PLATED OVERALL

3. CHARACTERISTICS:

- 3.1 ELECTRICAL CHARACTERISTICS;  
CONTACT RESISTANCE: 30mΩ MAXIMUM  
CONTACT CURRENT RATING: 1.5A  
DIELECTRIC WITHSTANDING VOLTAGE: 500 V R.M.S.  
INSULATION RESISTANCE 1000 MEGOHMS MIN  
OPERATING TEMPERATURE: -25°C ~ +85°C

3.2 MECHANICAL:

- MATING FORCE: 3.57Kg. Max.
- UNMATING FORCE: 1.02Kg. Min.

5. THE DIMENSIONS WITH "▼" MARK ARE CRITICAL AND SHOULD BE CONTROLLED BY QC.

图号 (DWG NO)	G-601-S1-548	单位 (UNIT): MM		显赫电子科技有限公司	
类别 (DWG TYPE)	SALES DWG	比例 (SCALE): 1:1		XianHe Electronic Technology co., ltd.	
版次 (REV): A/0	页次 (PAGE): 1/1		TEL: 0769-89138899 FAX: 0769-89100950		
设计 (DESIGN)	HCZ	未注公差 TOLERANCE UNSPECIFIED	品名 (ITEM NO)	ASP A/F 双层 90度 DIP 鱼叉脚 黑色半金 锡1U", 铜壳电镀 (材质: PA9T) 无卤	
审核 (CHECKED)		.X.X ± 0.38 .X.XX ± 0.20 .X.XXX ± 0.10 " ± 5° .X.X' ± 2'		料号 (PART NO)	601ASPAPHF
核准 (APPROVED)					