

RoHS Compliant

REV.	ECN NO	LTR	DESCRIPTION	REVISER	DATE
A/0			Initial release.	Mac	2010.08.20

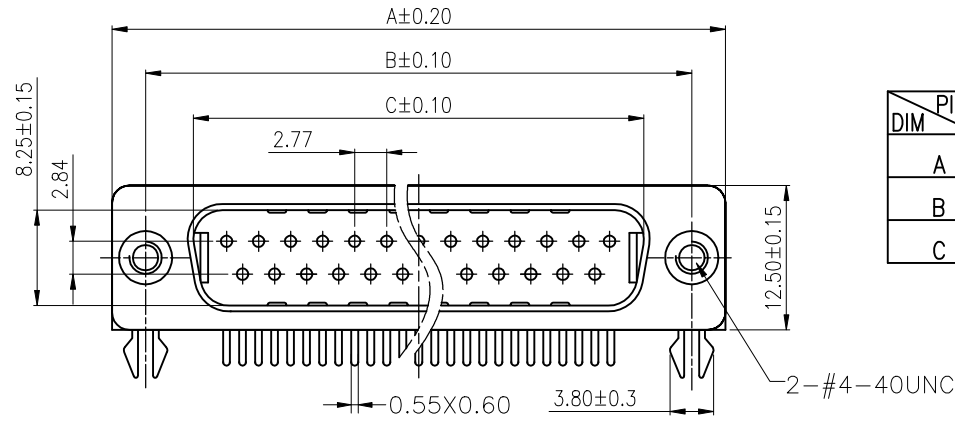

DIM \ PIN	DR9P	DR15P	DR25P	DR37P
A	30.80	39.20	53.05	69.40
B	25.00	33.30	47.05	63.50
C	16.90	25.25	38.95	55.40

- NOTE:
- MATERIAL:
 - INSULATOR:PBT+30%GF, UL94V-0, COLOR:OPTIONAL
 - COVER:PBT+30%GF, UL94V-0, COLOR:OPTIONAL
 - CONTACT: C2680R/H
 - SHELL:SPCC
 - PLATING:
 - CONTACT: SELECTIVE GOLD PLATED ON CONTACT AREA
80u" Min. TIN PLATED ON SOLDER TAIL
50u" Min. NICKEL UNDER-PLATED
 - SHELL:50u" Min. NICKEL PLATED OVERALL
 - CHARACTERISTICS:
 - ELECTRICAL CHARACTERISTICS:
CONTACT RESISTANCE:30mΩ MAXIMUM
CONTACT CURRENT RATING:3A
DIELECTRIC WITHSTANDING VOLTAGE:500 V R.M.S.
INSULATION RESISTANCE 1000 MEGOHMS MIN
OPERATING TEMPERATURE:-25°C ~ +85°C

PART NUMBER INFORMATION

305-XX-M-X-X-A-X-X

PIN NUMBER

- 09:09Pin
- 15:15Pin
- 25:25Pin
- 37:37Pin

- HSG. COLOR:
- K:BLACK
 - G:GREEN

- Rivet option:
- A: Screw assembly type.
 - 铁壳电镀 -B: Rivet
 - 1:镀镍12H -C: Rivet/screw assemble type.
 - 2:镀锡12H screw spec:4.75*5.8*13mm
 - 5:镀镍48H -D: rivet/screw attachment type.
 - screw spec:4.75*5.8*13mm

Terminal plating option:

- 1:Gold flash
- 5:Gold 15u"
- 6:Gold 30u"

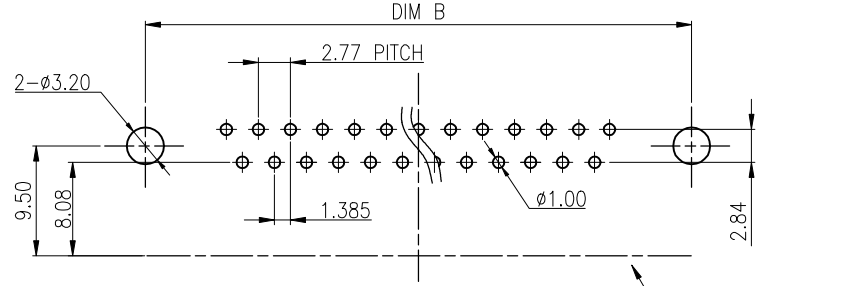
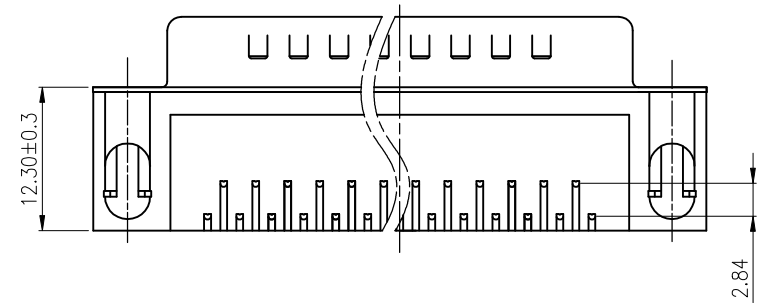
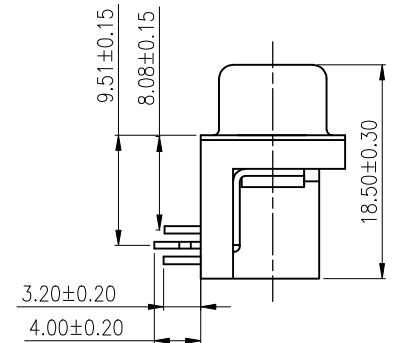

illustration of Rivet assembly

Type:A	Type:B\B1	Type:C	Type:D
			 此螺丝不用上在成品上, 附在箱里出货. #4-40UNC

图号 (DWG NO)	G-305-S1-8	单位 (UNIT):	MM
类别 (DWG TYPE)	SALES DWG	比例 (SCALE)	1:1
版次 (REV):	A/0	页次 (PAGE):	1/1
设计 (DESIGN)	Nelson	未注公差	TOLERANCE UNSPECIFIED
审核 (CHECKED)		.x.x	± 0.38
核准 (APPROVED)		x.xx	± 0.20
		x.xxx	± 0.10
		x'	± 5'
		x.x'	± 2'

显赫电子科技有限公司
XianHe Electronic Technology co., ltd.

TEL:0769-89138899 FAX:0769-89100950

品名 (ITEM NO) D-Sub R/A DIP Male

料号 (PART NO) Please see P/N information