

RoHS Compliant

REV.	ECN NO	LTR	DESCRIPTION	REVISER	DATE
A/0			Initial_release.	ZXW	2013/09/05

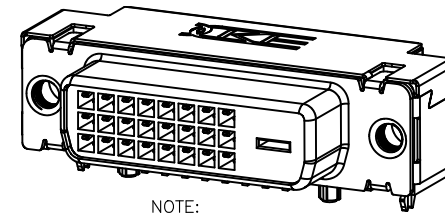
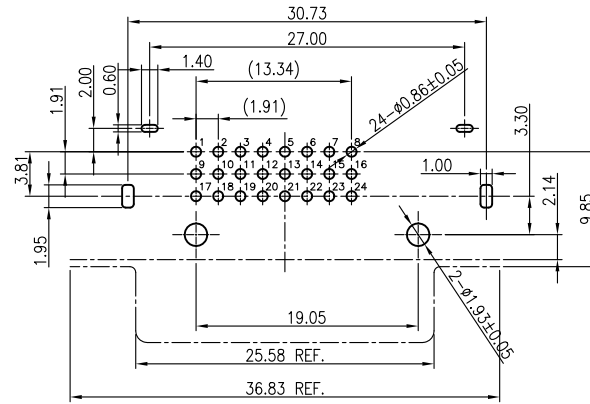
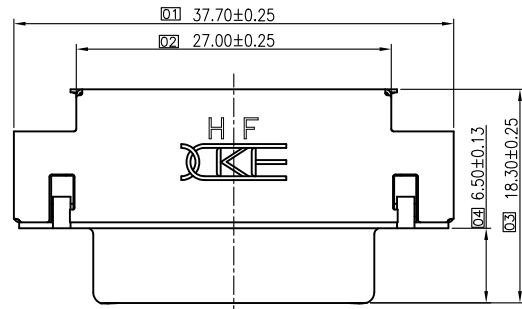

NOTE:
 1.MATERIAL:
 INSULATOR:HIGH TEMPERATURE+30%GLASS FIRBE UL94V-0 Halogen Free
 COLOR:WHITE
 TERMINAL:COPPER ALLOY
 TERMINAL PLATING:SELECTIVE GOLG PLATING ON CONTACT AREA.
 TIN 100U"MIN.ON SOLDER TAIL.

SEHL:SPCC-SD NICKEL PLATING.
 GROUNDING CLIP:BRASS TIN PLATING.
 NUT:COPPER ALLOY. NICKEL PLATING.

2.ELECTRICAL:
 INSULATOR RESISTANCE:1000MEGOHMS MIN.
 DIELECTRIC WITHSTANDING VOLTAGE:500V DC RMS.
 VOLTAGE TATING:40V AC RMS.CONTINUOUS MAX.
 CURRENT RATING:1.5A MIN. 3.0A MAX.
 CONTGACT RESISTANCE: 20 MILLLOHMS MAX.

3.ENVIRONMENTAL
 TEMPERATURE RANGE:-25°C TO + 85°C.

4.MECHANICAL
 MATING FORCE:4.5Kgf MAX.
 UNMATING FORCE:1.0~4.0 Kgf
 SCREW RECEDE AND TWIST FORCE:6.0±0.5Kgf

5.ROHS COMPLIANT.

6.Salt Spray Test Duration:Tin plated Area Test 24 hours.
 Other Areas Test 48 hours

产品单重: 8.23g
 客户料号: 388G354G0F2AXHCKHF

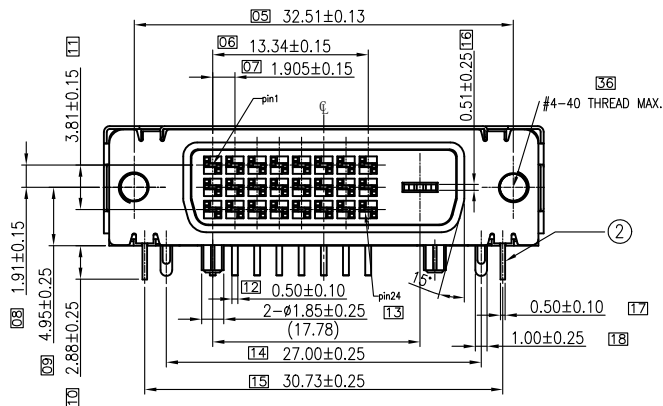

RECOMMENDED PCB LAYOUT
 T=1.6±0.05mm

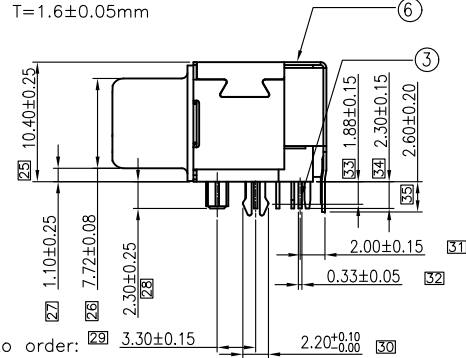

6.How to order:
 331-24-W-1-A-D-C-AOC-HF

24Pin.
 Hsg.color:
 ✓W: white
 B: black
 Terminal plating:
 ✓V: Gold flash on contact area.
 100u"Min tin plating on solder tail.

Install option:
 ✓D: DIP.
 degree:
 ✓A: 90°

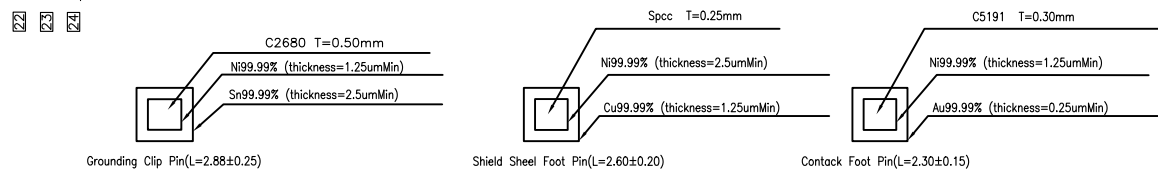
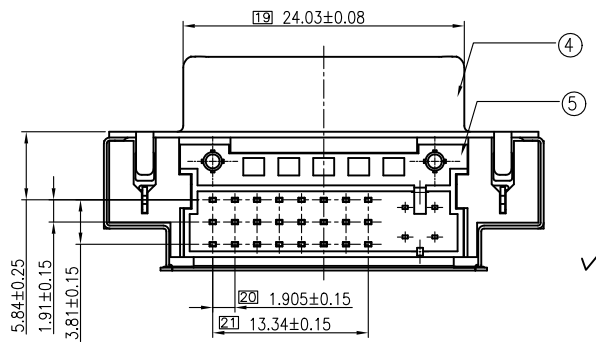

No.	ITEM	Q'TY	MATERIAL DISCRPTION	REMARK
⑥	SHIELD SHELL	1PCS	SPCC	100U"Min. NICKEL PLATING ON SURFACE. 50U"MIN. CU PLATING ON BASE.
⑦	HOUSING & COVER	1PCS	PA66	PA66+30% GLASS FIBER UL94V-0 COLOR WHITE Halogen Free
④	SHELL	1PCS	SPCC	100U"Min. NICKEL PLATING ON SURFACE. 50U"MIN. CU PLATING ON BASE.
③	TERMINAL	24PCS	C5191	GOLD 1u" ON CONTACT AREA AND 100U" TIN ON SOLDER TAIL, 50U"MIN. NICKEL PLATING ON BASE.
②	GROUNDING CLIP	2PCS	C2680	100U"Min. TIN PLATING ON SURFACE. 50U"MIN. NICKEL PLATING ON BASE.
①	SCREW	2PCS	FERROALLOY	100U"Min. NICKEL PLATING ON SURFACE. 50U"MIN. CU PLATING ON BASE.

图号 (DWG NO)	G-331-S2-24	单位 (UNIT):	MM
类别 (DWG TYPE)	ENG DWG	比例 (SCALE):	1:1
版次 (REV):	A/0	页次 (PAGE):	1/1
设计 (DESIGN)	ZXW	未注公差	TOLERANCE UNSPECIFIED
审核 (CHECKED)		X.X ±0.38	
核准 (APPROVED)		X.XX ±0.13	
		X* ±3*	

显赫电子科技有限公司
 XianHe Electronic Technology co., ltd.
 TEL:0769-89138899 FAX:0769-89100950

品名 (ITEM NO): DVI 24+0母白色GF90度DIP铆合 无螺丝 屏蔽罩DIP脚2.60mm(AOC)环保无卤

料号 (PART NO): 33124W1ADA0OCHF

产品单重: 8.23g
 AOC料号: 088G 35424FXNH