

RoHS Compliant

REV.	ECN NO	LTR	DESCRIPTION	REVISER	DATE
A/0			Initial release.	Joe.peng	2017.11.27
A/1		△	增加重点符号	GENG	2020.07.31

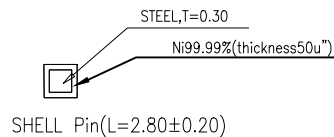
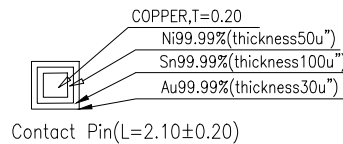
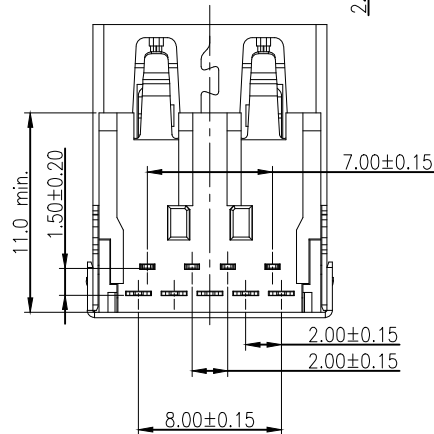
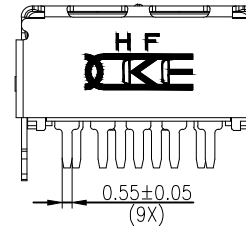
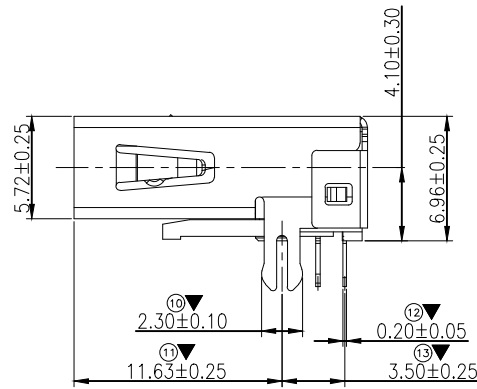
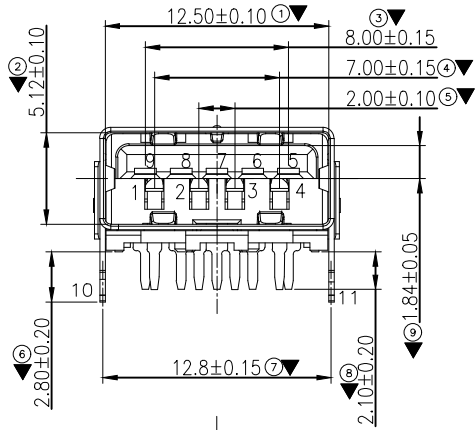
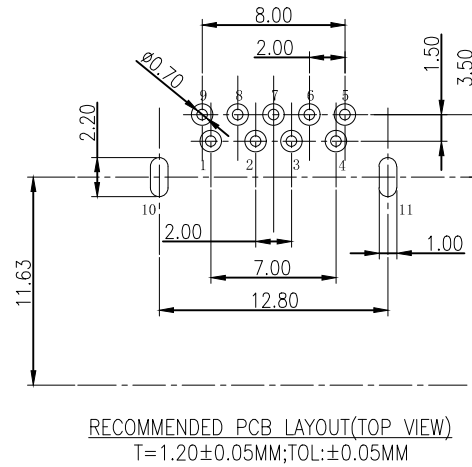
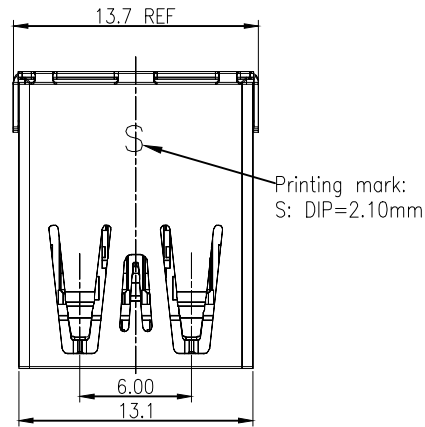

NOTE:

1.MATERIAL:

- 1.1 INSULATOR:LCP+30%GF, UL94V-0, COLOR:BLUE
- 1.2 COVER:LCP+30%GF, UL94V-0, COLOR:BLUE
- 1.3 CONTACT 1~4PIN: C5191R/H T=0.25MM,
- 1.4 CONTACT 5~9PIN: C2680R/H T=0.20MM,
- 1.5 SHELL:STAINLESS STEEL T=0.3MM

2. PLATING:

- 2.1 CONTACT: Au 30u" PLATED ON CONTACT AREA 100u" Min. MATTE TIN PLATED ON SOLDER TAIL 50u" Min. NICKEL UNDER-PLATED
- 2.2 SHELL:20u" Min. NICKEL PLATED OVERALL

3. CHARACTERISTICS:

- 3.1 ELECTRICAL CHARACTERISTICS;
CONTACT RESISTANCE:30mΩ MAXIMUM
CONTACT CURRENT RATING:1.5A
DIELECTRIC WITHSTANDING VOLTAGE:500 V R.M.S.
INSULATION RESISTANCE 100 MEGOHMS MIN
OPERATING TEMPERATURE:-25°C ~ +85°C

3.2 MECHANICAL:

- MATING FORCE: 3.57Kg.Max.
UNMATING FORCE: 1.02Kg.Min.

4. DESIGN STANDARD ACCORDING TO USB_3.0 SPECIFICATION.

5. THE DIMENSIONS WITH "▼" MARK ARE CRITICAL
△ AND SHOULD BE CONTROLLED BY QC.

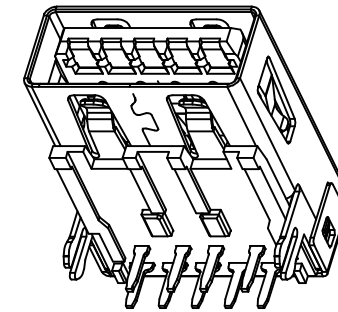

图号 (DWG NO)	G-601-S2-5	单位 (UNIT): MM	显赫电子科技有限公司 XianHe Electronic Technology co., Ltd. TEL:0769-89138899 FAX:0769-89100950	
类别 (DWG TYPE)	ENG DWG	比例 (SCALE) 1:1		
版次 (REV): A/1	页次 (PAGE): 1/1		品名 (ITEM NO)	ASP A/F R/A LCP DIP=2.10MM
设计 (DESIGN)	Joe.peng	未注公差 TOLERANCE UNSPECIFIED	料号 (PART NO)	601ASPB5HF
审核 (CHECKED)		X.X ± 0.15 X.XX ± 0.10 X.XXX ± 0.05 X ± 2 X.X ± 1		
核准 (APPROVED)				