

RoHS Compliant

REV.	ECN NO	LTR	DESCRIPTION	REVISER	DATE
A/0			Initial release.	Mac	2016.07.13

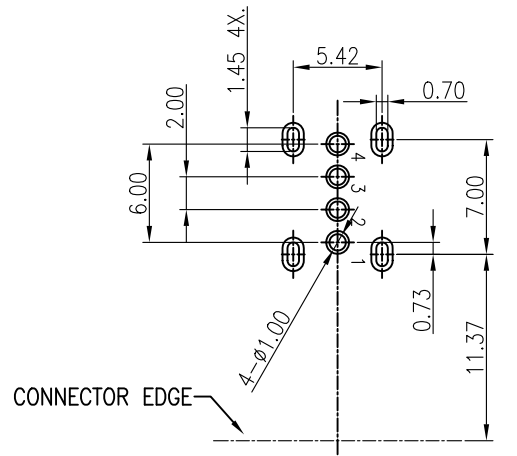
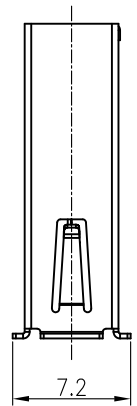

RECOMMENDED PCB LAYOUT (TOP VIEW)
TOLERANCE: ±0.05, THICKNESS=1.6mm

NOTE:

1. MATERIAL:
 - 1.1 INSULATOR: PA9T+30%GF, UL94V-0, COLOR: OPTIONAL
 - 1.2 COVER: PA9T+30%GF, UL94V-0, COLOR: OPTIONAL
 - 1.3 CONTACT: C5191R/H,
 - 1.4 FRONT SHELL: BRASS T=0.3MM
 - 1.5 BACK SHELL: BRASS
2. PLATING:
 - 2.1 CONTACT: SELECTIVE GOLD PLATED ON CONTACT AREA 100u" Min. MATTE TIN PLATED ON SOLDER TAIL 50u" Min. NICKEL UNDER-PLATED
 - 2.2 FRONT SHELL: 50u" Min. NICKEL PLATED OVERALL
 - 2.3 BACK SHELL: 50u" Min. NICKEL PLATED OVERALL
3. CHARACTERISTICS:
 - 3.1 ELECTRICAL CHARACTERISTICS;
 - CONTACT RESISTANCE: 30mΩ MAXIMUM
 - CONTACT CURRENT RATING: 1.5A
 - DIELECTRIC WITHSTANDING VOLTAGE: 500 V R.M.S.
 - INSULATION RESISTANCE 1000 MEGOHMS MIN
 - OPERATING TEMPERATURE: -40°C ~ +125°C
 - 3.2 MECHANICAL:
 - MATING FORCE: 3.57Kg.Max.
 - UNMATING FORCE: 1.02Kg.Min.

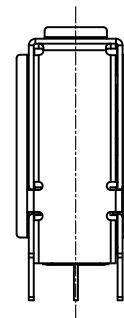
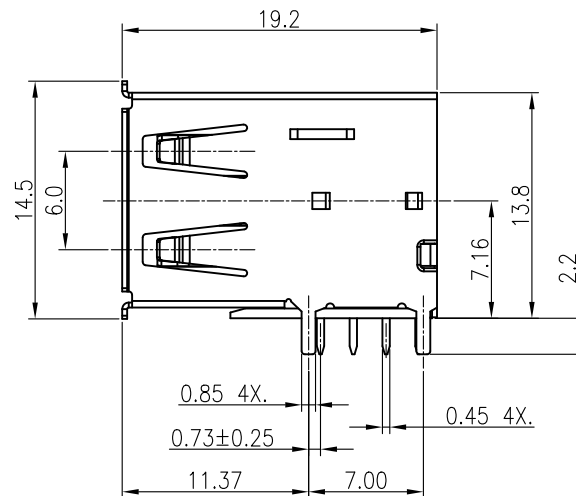
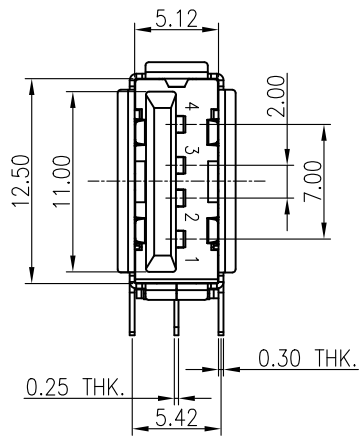

PART NUMBER INFORMATION
319AF-X-J9-X-BN

Hsg.color: B:Blue, K:Black
Terminal plating: 1: Gold flash, 5: Gold plated 15u", 6: Gold plated 30u"

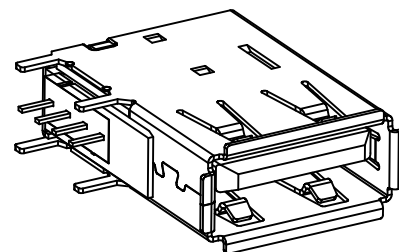
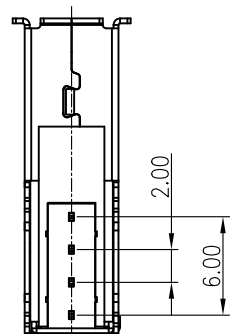

3D VIEW

图号 (DWG NO)	G-319-S1-606	单位 (UNIT):	MM	显赫电子科技有限公司 XianHe Electronic Technology co., ltd.	
类别 (DWG TYPE)	SALES DWG	比例 (SCALE)	1:1		
版次 (REV):	A/0	页次 (PAGE):	1/1	TEL:0769-89138899 FAX:0769-89100950	
设计 (DESIGN)	Nelson	未注公差	TOLERANCE UNSPECIFIED X.X ± 0.38 X.XX ± 0.20 X.XXX ± 0.10 X" ± 5' X.X' ± 2"	品名 (ITEM NO)	USB A/F UPRIGHT STRAIGHT TAILS, DIP=2MM
审核 (CHECKED)				料号 (PART NO)	Please see P/N information
核准 (APPROVED)					