

RoHS Compliant

REV.	ECN NO	LTR	DESCRIPTION	REVISER	DATE
A/1			图面更新	XIE	2020.05.12
A/2		△	客户要求新光PBT料	HCZ	2020.06.01

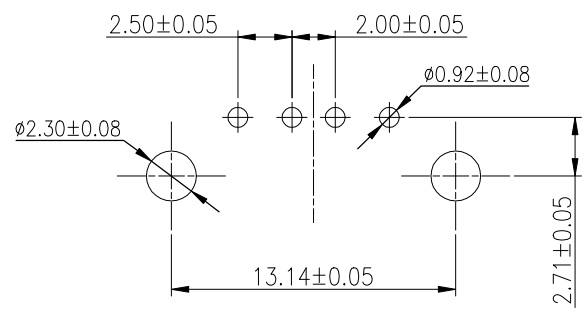
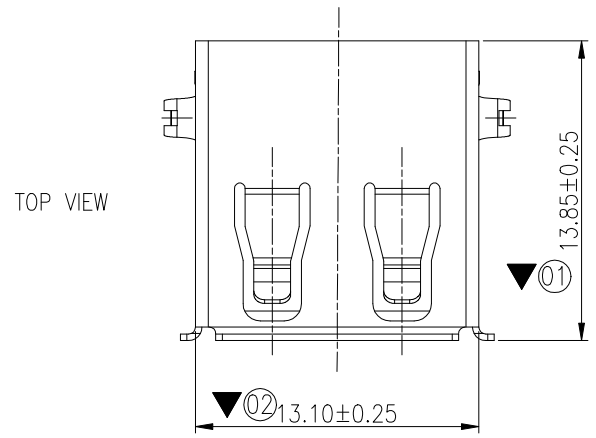

RECOMMENDED P.C.B LAYOUT
COMPONENT SIDE OF BOARD

- NOTE:
- MATERIAL:
 - INSULATOR:LCP&PBT, UL94V-0, COLOR:OPTIONAL (SHINKONG PBT E202G30) △
 - CONTACT:C5191-H T=0.25MM,
 - SHELL:C2680-EH T=0.30MM
 - PLATING:
 - CONTACT: SELECTIVE GOLD PLATED ON CONTACT AREA 100u" Min. TIN PLATED ON SOLDER TAIL 50u" Min. NICKEL UNDER-PLATED
 - SHELL:50u" Min. NICKEL PLATED OVERALL
 - CHARACTERISTICS:
 - ELECTRICAL CHARACTERISTICS; CONTACT RESISTANCE:30mΩ MAXIMUM CONTACT CURRENT RATING:1.5A DIELECTRIC WITHSTANDING VOLTAGE:500 V R.M.S. INSULATION RESISTANCE 1000 MEGOHMS MIN OPERATING TEMPERATURE:-40°C ~ +85°C
 - MECHANICAL: MATING FORCE: 3.57Kg.Max. UNMATING FORCE: 1.02Kg.Min.
 - DESIGN STANDARD ACCORDING TO USB_2.0 SPECIFICATION.
 - THE DIMENSIONS WITH"▼"MARK ARE CRITICAL

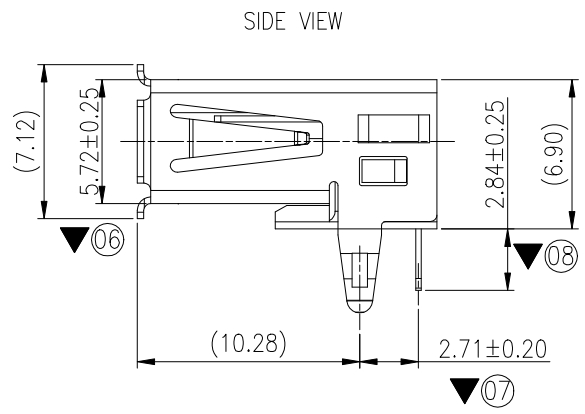
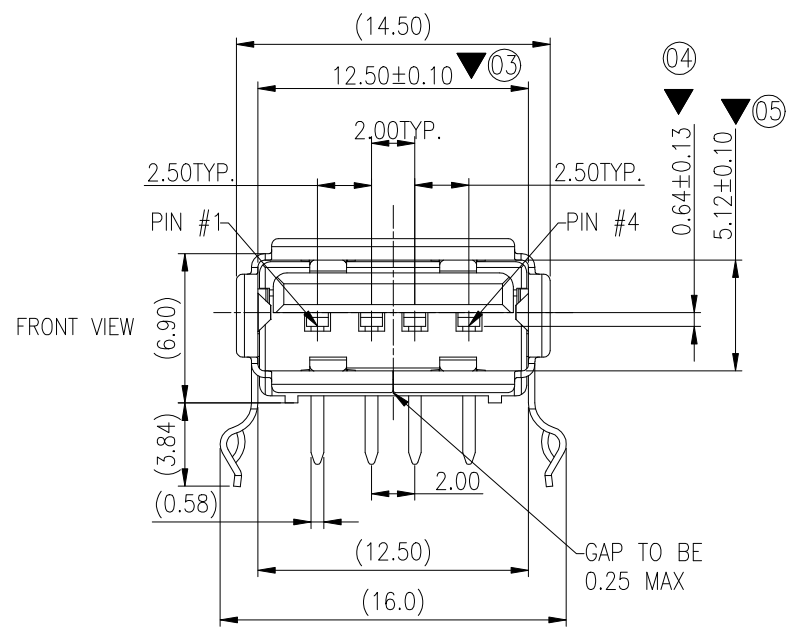

PART NUMBER INFORMATION
319AF-K-XX-X-BN-XX

Hsg.color: K:Black

HF: Halogen Free
W/O HF: RoHS

Terminal plating:
1: Gold flash
4: Gold 15u" on contact area.
6: Gold 30u" on contact area.

REV: S8:PBT, S9:LCP

图号 (DWG NO)	G-319-S1-361	单位 (UNIT):	MM	显赫电子科技有限公司 XianHe Electronic Technology co., ltd.	
类别 (DWG TYPE)	SALES DWG	比例 (SCALE):	1:1		
版次 (REV):	A/2	页次 (PAGE):	1/1	TEL:0769-89138899 FAX:0769-89100950	
设计 (DESIGN)	XIE	未注公差	TOLERANCE UNSPECIFIED	品名 (ITEM NO)	USB 2.0 A/F R/A DIP H=6.9MM FOR APH
审核 (CHECKED)		.X.X	± 0.38	料号 (PART NO)	Please see P/N information
核准 (APPROVED)		.X.XX	± 0.25		
		.X.XXX	± 0.10		
		X'	± 5'		
		X.X'	± 2'		