

RoHS Compliant

REV.	ECN NO	LTR	DESCRIPTION	REVISER	DATE
A/0			Initial_release.	WB	2021.07.09

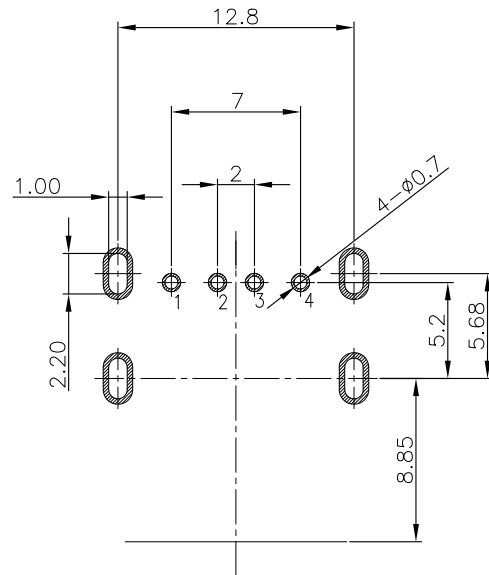
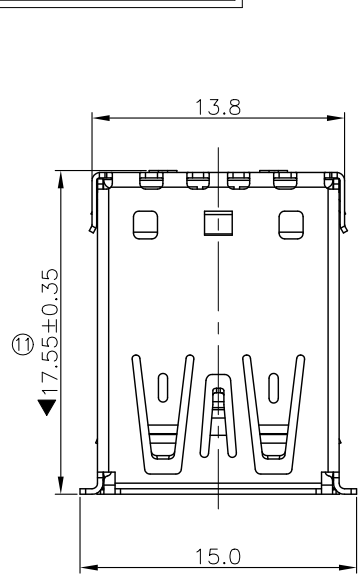

PCB LAYOUT(TOP VIEW T=1.60)

NOTE:

1. MATERIAL:
 - 1.1 INSULATOR:LCP BLACK,UL94-V0.
 - 1.2 COVER:LCP BLACK,UL94V-0
 - 1.3 CONTACT: C5191.
 - 1.4 SHELL:SUS304
2. PLATING:
 - 2.1 CONTACT: GOLD FLASH PLATED ON CONTACT AREA 100u" Min. MATTE TIN PLATED ON SOLDER TAIL 50u" Min. NICKEL UNDER-PLATED
 - 2.2 SHELL:20u" Min. NICKEL PLATED OVERALL
3. CHARACTERISTICS:
 - 3.1 ELECTRICAL CHARACTERISTICS;
 - CONTACT RESISTANCE:30mΩ MAXIMUM
 - CONTACT CURRENT RATING:1.5A
 - DIELECTRIC WITHSTANDING VOLTAGE:500 V R.M.S.
 - INSULATION RESISTANCE 1000 MEGOHMS MIN
 - OPERATING TEMPERATURE:-25°C ~ +85°C
 - 3.2 MECHANICAL:
 - MATING FORCE: 3.57Kg.Max.
 - UNMATING FORCE: 1.02Kg.Min.
4. DESIGN STANDARD ACCORDING TO USB_2.0 SPECIFICATION.
5. THE DIMENSIONS WITH"▼"MARK ARE CRITICAL AND SHOULD BE CONTROLLED BY QC.

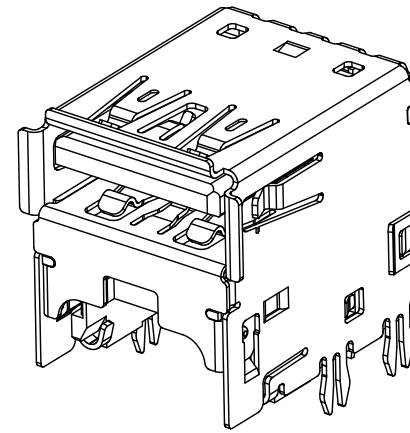
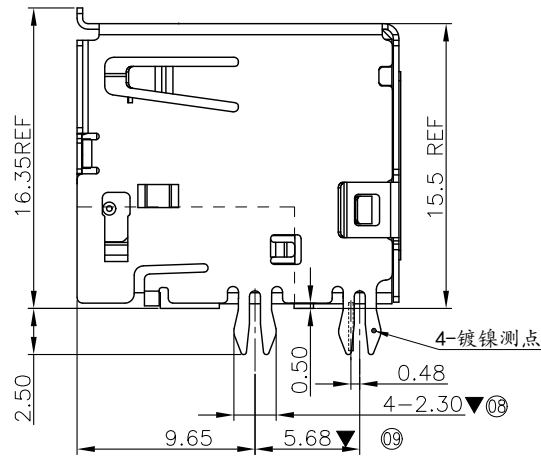
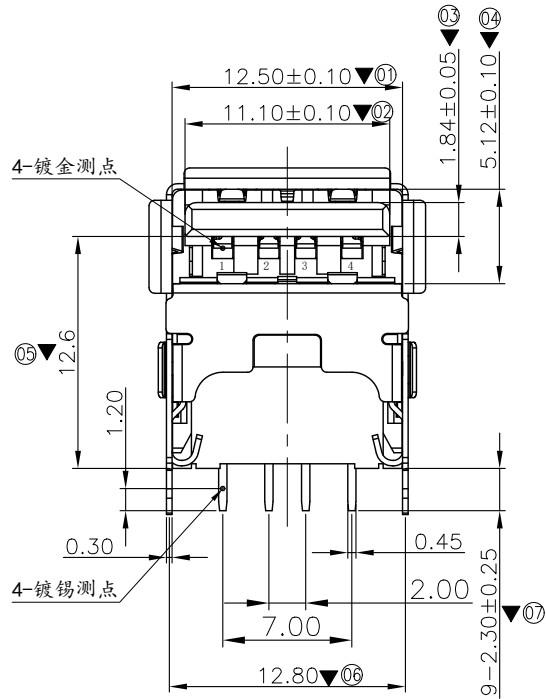

PIN ASSIGNMENT

PIN NUMBER	SIGNAL NAME
1	VBUS
2	D-
3	D+
4	GND
SHELL	SHIELD

图号 (DWG NO)	G-319-S1-591	单位 (UNIT):	MM	显赫电子科技有限公司 XianHe Electronic Technology co., ltd.
类别 (DWG TYPE)	BRKE DWG	比例 (SCALE)	1:1	
版次 (REV):	A/0	页次 (PAGE):	1/3	TEL:0769-89138899 FAX:0769-89100950
设计 (DESIGN)	WB	未注公差	TOLERANCE UNSPECIFIED	品名 (ITEM NO)
审核 (CHECKED)		.X.X	± 0.38	
核准 (APPROVED)		.X.XX	± 0.20	
		.X.XXX	± 0.10	料号 (PART NO)
		"	± 5"	
		.X.X"	± 2"	USB 2.0 A/F 90度加高型DIP, CH=12.6mm,有卷边鱼叉脚, DIP=2.5mm,LCP黑色,半金雾锡G/F,不锈钢外壳镀镍,盐雾48H,真空盒包装,环保
				319AFKV5LSN

RoHS Compliant

REV.	ECN NO	LTR	DESCRIPTION	REVISER	DATE
A/0			Initial_release.	WB	2021.07.09

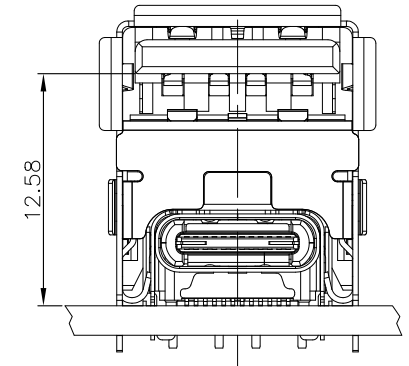
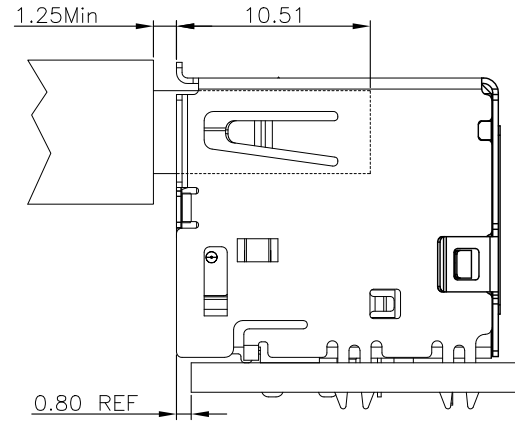
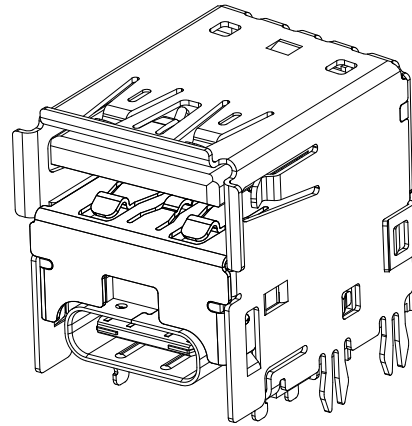
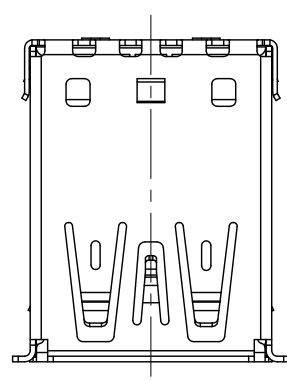

RECOMMENDED MOUNTING CONFIGURATION

HIGE RISE USB2.0+USB TYPE-C

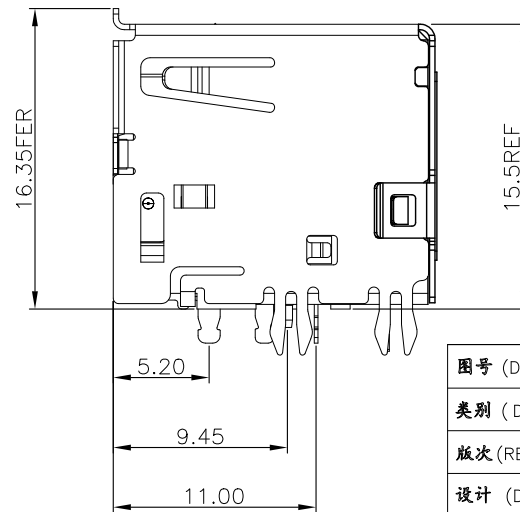
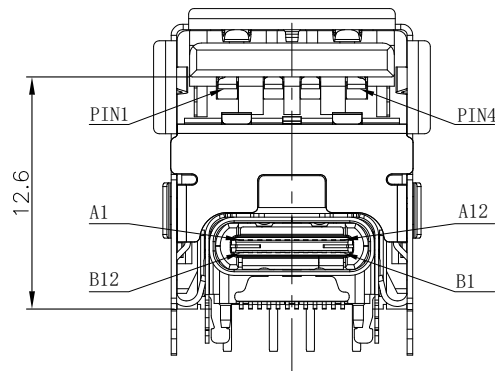

图号 (DWG NO)	G-319-S1-591	单位 (UNIT):	MM	 显赫电子科技有限公司 XianHe Electronic Technology co., Ltd.
类别 (DWG TYPE)	BRKE DWG	比例 (SCALE)	1:1	
版次 (REV):	A/0	页次 (PAGE):	2/3	TEL:0769-89138899 FAX:0769-89100950
设计 (DESIGN)	WB	未注公差	TOLERANCE UNSPECIFIED	品名 (ITEM NO) USB 2.0 A/F 90度加高型DIP, CH=12.6mm, 有卷边鱼叉脚, DIP=2.5mm, LCP黑色, 半金雾锡G/F, 不锈钢外壳镀镍, 盐雾48H, 真空盒包装, 环保
审核 (CHECKED)		X.X	± 0.38	
核准 (APPROVED)		X.XX	± 0.20	
		X.XXX	± 0.10	料号 (PART NO)
		X"	± 5'	
		X.X"	± 2'	

